

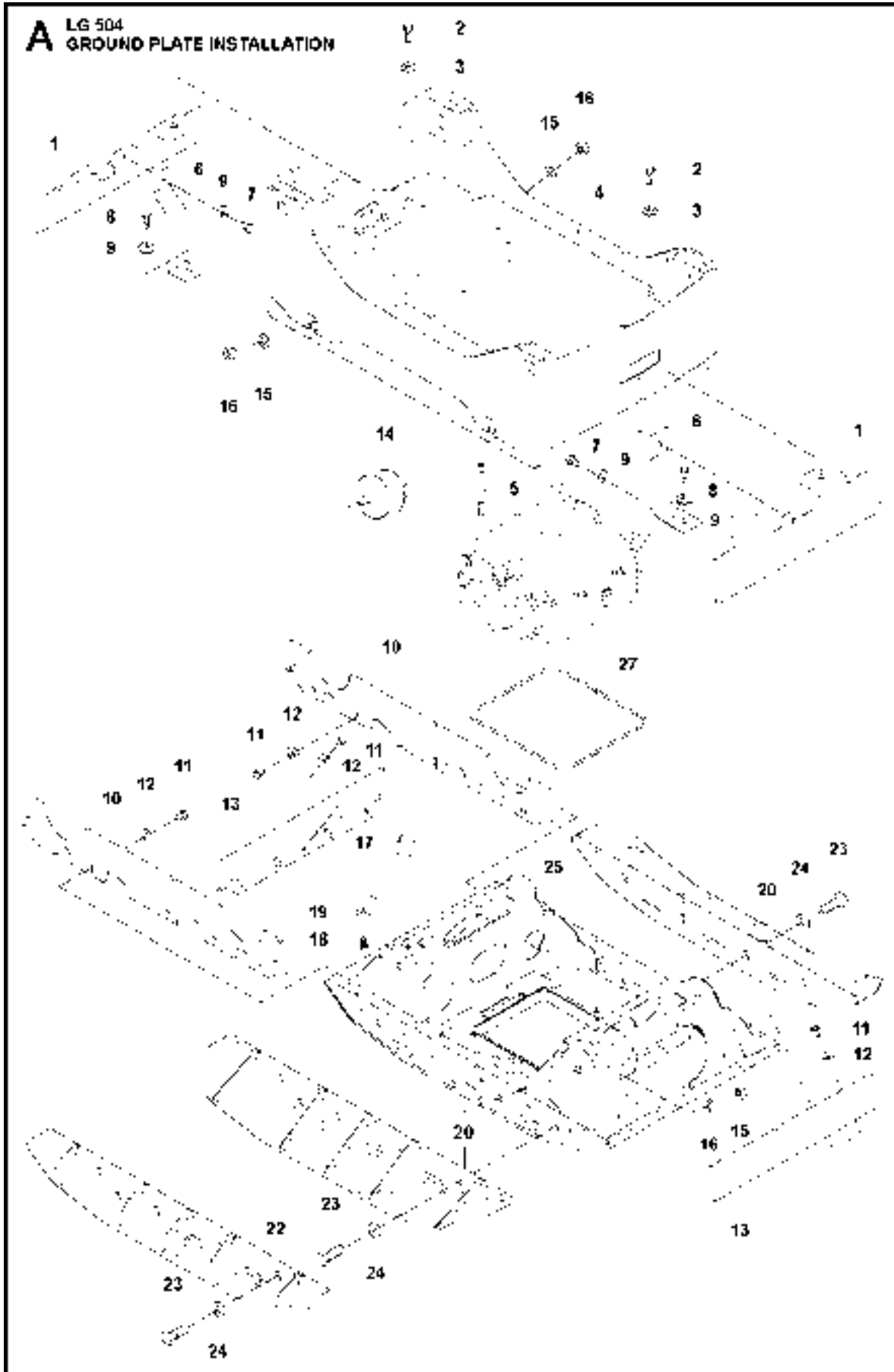

SPARE PARTS LIST

LIGHT COMPACTION

LG 504, 967855501, 967855502,
967855503, 967855504, 967855505,
967855506, 967855507, 967855508,
967855509, 967855510, 967855511,
967855512, 2019-08



GROUND PLATE INSTALLATION LG 504, 967855501, 967855502, 967855503, 967855504, 967855505, 967855506, 967855507, 967855508, 967855509, 967855510, 967855511, 967855512,

Ref	Part No	Description	Remark	QTY KIT
1	594 75 68-01	COVER		2
2	595 11 03-01	SCREW	M12 x 035H, 8.8, A3K	4
3	595 06 65-01	WASHER		4
4	594 75 67-01	ENGINE PLATE		1
5	594 12 10-01	SOCKET	M12 x 120 12.9 DIN 912	10
6	594 14 15-01	STRAP		2
7	595 34 52-01	BOLT	M6 x 20 mm 8.8 A2K	2
8	595 34 52-01	BOLT	M12 x 020H, 8.8 A3K	2
9	594 12 40-01	WASHER	"0.51x1.42x0.24"" 300HV"	4
10	594 18 21-01	COVER		2
11	595 34 46-01	SCREW	M10x16	18
12	594 12 35-01	PLANE WASHER	10,5x30,0x2,5 DIN 9021	18
13	595 12 72-01	COVER		2
14	594 18 70-01	ABSORBER		4
15	595 03 58-01	NUT	M1 6x 2,00 -8, A3K	8
16	595 03 67-01	WASHER	M16 17,0x30x3,0 300 HV	8
17	594 18 51-01	STOP		4
18	595 34 46-01	SCREW	M10 x 16	4
19	594 74 74-01	WASHER	M10 10,5x22x2,0 300 HV	4
20	594 18 87-01	PLATE	150 mm	2
22	595 12 87-01	PLATE	75 mm	2
23	594 11 94-01	SCREW	DIN933 M20x050H, 8.8, A9K	8
24	594 12 43-01	WASHER	21x36x6 conical	8
25	594 18 20-01	GROUND PLATE		1
27	594 75 99-01	O-RING	Ø325x3	1

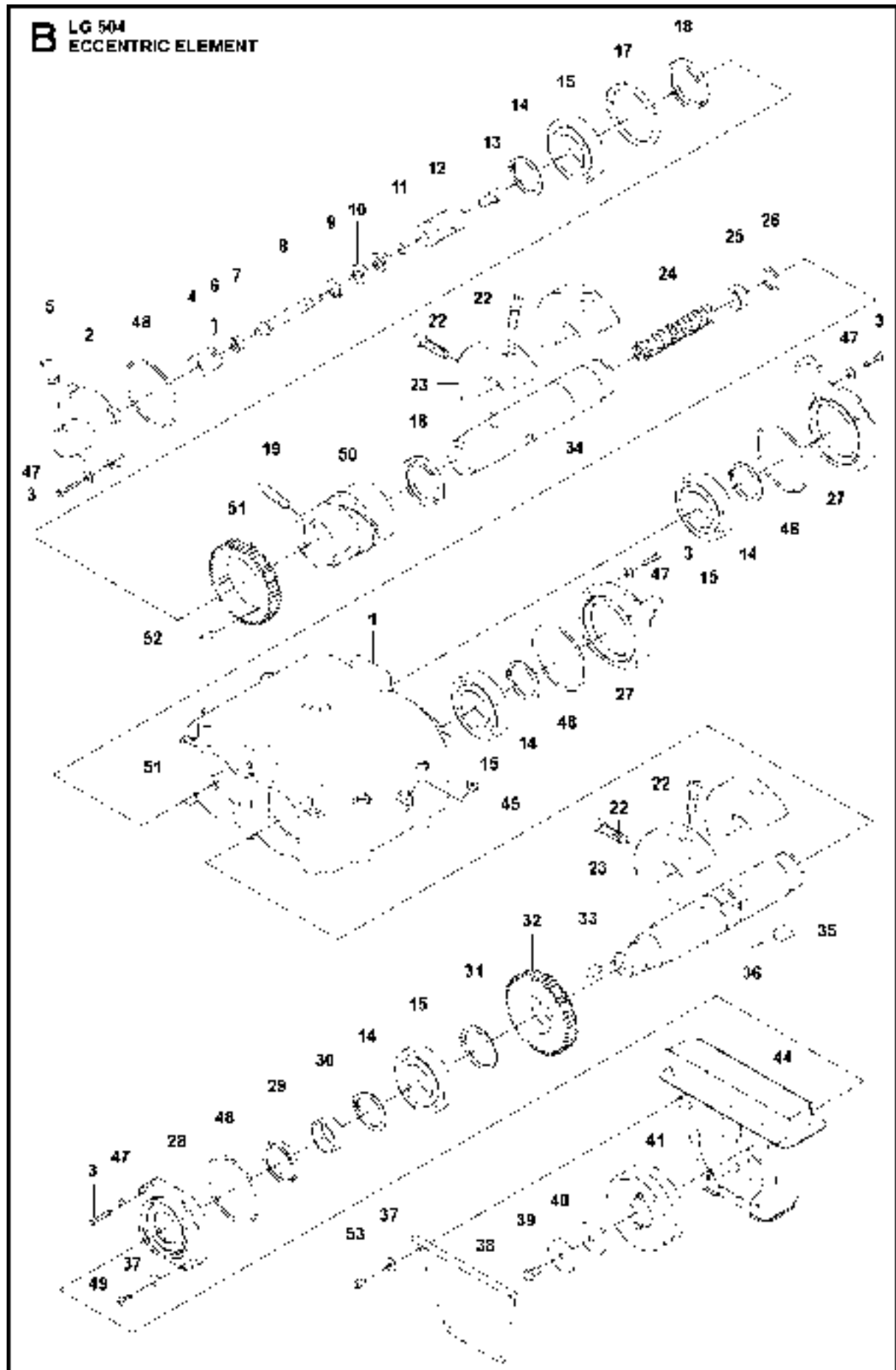

ECCENTRIC ELEMENT LG 504, 967855501, 967855502, 967855503, 967855504, 967855505, 967855506, 967855507, 967855508, 967855509, 967855510, 967855511, 967855512, 2019-08

Ref	Part No	Description	Remark	QTY KIT
1	594 17 95-01	HOUSING		1
2	594 17 52-01	HYDRAULIC CYLINDER		1
3	595 28 74-01	SCREW		16
4	594 64 30-01	CAP		1
5	594 12 75-01	NIPPLE		1
6	595 03 11-01	PIN	Ø6 x 20 mm DIN 1481	1
7	594 18 43-01	SEALING		1
8	594 18 23-01	PISTON ROD		1
9	595 11 39-01	CIRCLIP		1
10	594 18 36-01	BALL BEARING		2
11	595 04 63-01	RING	For hole position 28 (in image)	1
12	594 18 24-01	PISTON		1
13	594 44 39-01	STOP SCREW		1
14	595 03 72-01	CIRCLIP		4
15	594 18 34-01	BEARING		4
17	594 12 49-01	CIRCLIP		1
18	594 54 76-01	BALL BEARING		2
19	594 18 67-01	PIN		1
22	595 03 47-01	SCREW	M12 x 045H 8.8 A3K	8
23	594 17 97-01	EXCENTER		4
24	594 18 35-01	SPRING		1
25	594 32 28-01	STOP		1
26	595 03 74-01	CIRCLIP		1
27	594 18 68-01	COVER		2
28	594 19 17-01	BEARING COVER		1
29	594 18 42-01	RADIAL SEAL		1
30	594 54 75-01	RING		1
31	594 12 48-01	CIRCLIP		2
32	594 17 49-01	GEAR		1
33	595 05 08-01	KEY		1
34	594 17 98-01	SHAFT		1
35	594 18 75-01	KEY		1
36	594 17 53-01	SHAFT		1
37	595 03 64-01	WASHER	DIN 9021	12
38	594 19 18-01	COVER		1
39	594 11 84-01	SCREW	M10x20 mm 8.8 A3K	1
40	594 32 16-01	WASHER		2
41	595 37 49-01	PULLEY		1
44	594 19 19-01	BELT COVER		1
45	595 35 53-01	PLUG		1
47	594 12 46-01	WASHER		16
48	595 03 97-01	O-RING		4
49	595 34 94-01	SCREW		8
50	594 17 99-01	GEAR		1
51	594 17 50-01	GEAR		1
52	594 54 70-01	KEY		1
53	595 34 79-01	SOCKET	M6x12	4

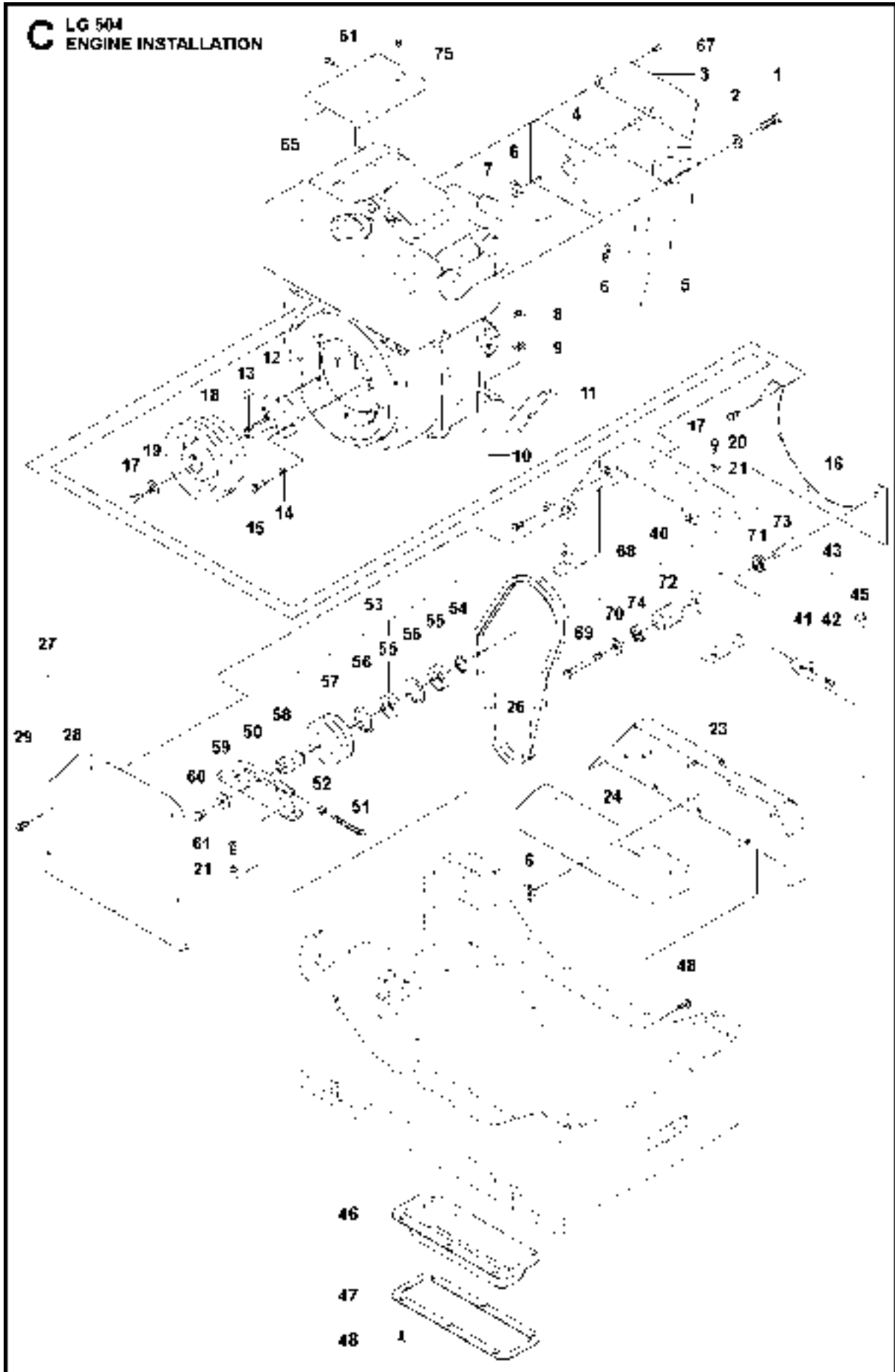

ENGINE INSTALLATION LG 504, 967855501, 967855502, 967855503, 967855504, 967855505, 967855506, 967855507, 967855508, 967855509, 967855510, 967855511, 967855512, 2019-08

Ref	Part No	Description	Remark	QTY	KIT
1	594 12 09-01	BOLT		2	
2	595 06 65-01	WASHER		2	
3	594 75 71-01	PROTECTION		1	
4	594 75 70-01	INSULATION		1	
5	594 75 69-01	INSULATION		1	
6	595 05 17-01	WASHER		12	
7	595 36 74-01	EXHAUST PIPE		1	
8	594 54 86-01	NUT		4	
9	595 06 79-01	WASHER		4	
10	594 48 61-01	SCREW		4	
11	595 05 00-01	BRACKET		1	
12	594 33 05-01	SHAFT		1	
13	594 36 82-01	KEY		1	
14	595 06 73-01	WASHER		4	
15	595 34 43-01	SCREW		4	
16	594 82 75-01	COVER		1	
17	594 11 84-01	SCREW		6	
18	594 64 68-01	CLUTCH		1	
19	595 06 65-01	WASHER		1	
20	595 34 83-01	SOCKET		6	
21	595 03 66-01	WASHER		8	
23	594 75 97-01	INSULATION		1	
24	594 75 77-01	INSULATION		1	
26	594 18 91-01	V-BELT	XPA 1208(6T43)	2	
27	595 27 65-01	COVER		1	
28	595 08 90-01	BELT COVER		1	27
29	594 11 99-01	SCREW		5	27
40	594 18 08-01	V-BELT		1	
41	594 32 95-01	CLIP		2	43
42	594 32 94-01	SCREW		2	43
43	594 33 69-01	HOSE		1	
45	595 04 96-01	HOSE		1	43
46	594 16 45-01	PROTECTION		1	
47	594 75 30-01	FLANGE		1	
48	595 03 44-01	SCREW		11	
50	594 18 28-01	BRACKET		1	
51	594 11 95-01	SCREW	H M10 x 90 CL8.8 DIN933 ZnB	1	
52	595 02 94-01	NUT	M10 DIN 934-8 Zn	1	
53	594 43 14-01	BELT		1	
54	595 04 55-01	SNAP RING		1	53
55	594 25 91-01	BALL BEARING		2	53
56	595 04 61-01	SNAP RING		2	53
57	594 44 01-01	BELT		1	53
58	594 43 15-01	SHAFT		1	53
59	594 12 40-01	WASHER		1	
60	595 34 53-01	SCREW		1	
61	595 03 45-01	SCREW	M8 x 25	2	
65	596 24 12-06	ENGINE		1	
67	595 34 79-01	SOCKET	M6 x 12	1	
68	594 19 24-01	BELT GUIDE		1	
69	595 34 50-01	SCREW	M10 x 100, 8.8, A3K	1	68
70	594 74 74-01	WASHER		1	68
71	594 19 27-01	BALL BEARING		1	68
72	594 19 23-01	BELT		1	68
73	594 19 26-01	SHAFT		1	68
74	594 12 65-01	BALL BEARING		1	68
75	595 37 08-01	PROTECTION	Heat protection	1	

D LG 504
ENGINE - HATZ 1D81Z

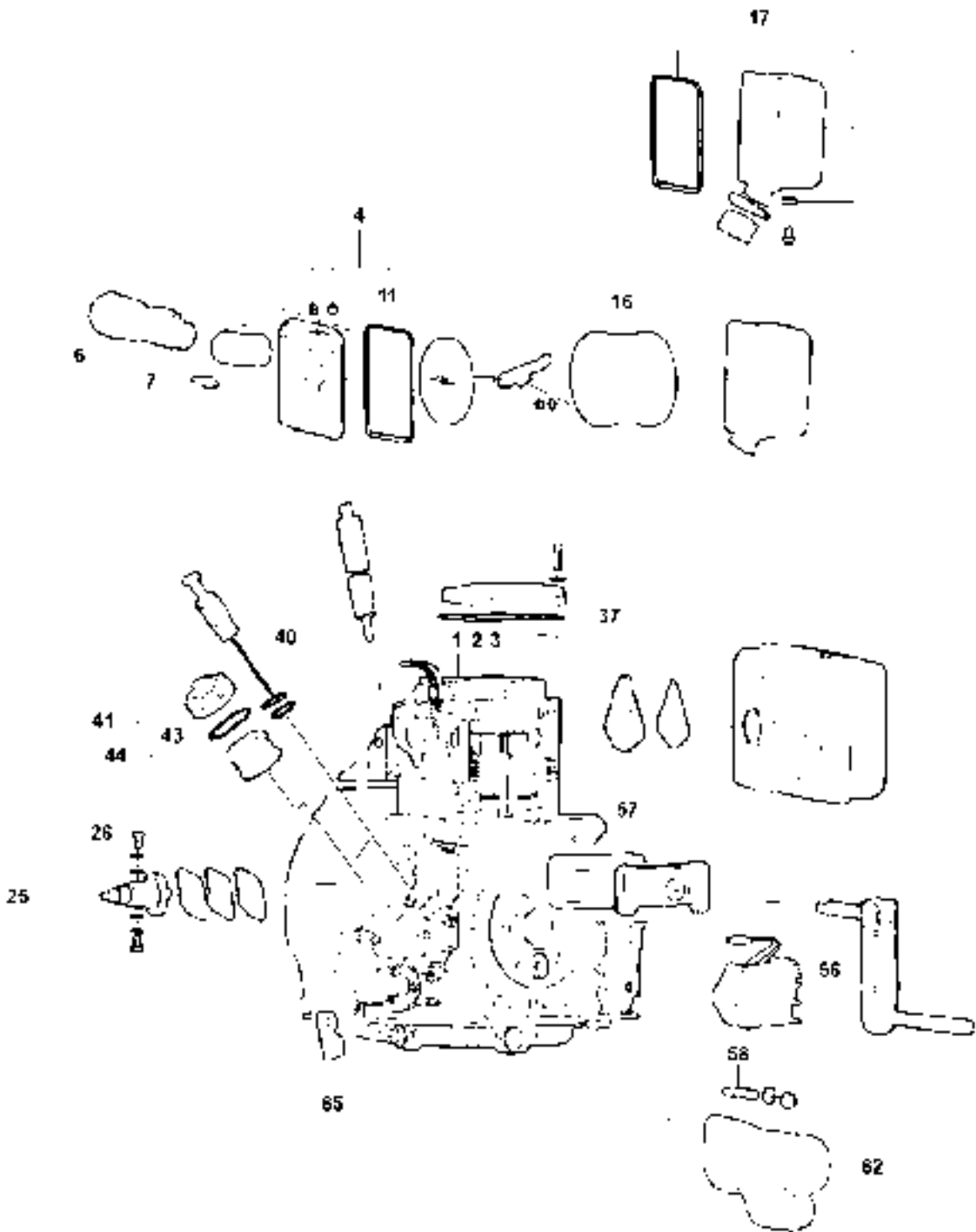

ENGINE LG 504, 967855501, 967855502, 967855503, 967855504, 967855505, 967855506, 967855507, 967855508, 967855509, 967855510, 967855511, 967855512, 2019-08

Ref	Part No	Description	Remark	QTY	KIT
1	596 24 12-06	ENGINE	Hatz 1D81Z-342A El. start EU	1	
2	595 37 32-01	ENGINE	Hatz 1D81Z El. EPA	1	
3	596 24 12-07	ENGINE	ENGINE Hatz, 1D81Z Man	1	
4	594 20 76-01	AIR FILTER COVER		1	
6	594 31 34-01	ELBOW		1	4
7	594 57 15-01	NUT		1	4
11	594 30 83-01	GASKET		1	4
16	594 30 54-01	AIR FILTER		1	
17	594 30 75-01	HOUSING		1	
25	594 60 90-01	FUEL PUMP		1	
26	594 20 73-01	BOLT		2	25
37	594 30 28-01	GASKET		1	
40	595 13 18-01	O-RING		2	
41	594 55 73-01	COVER		1	
43	594 30 29-01	GASKET		1	41, 44
44	595 37 25-01	OIL FILTER		1	
56	594 60 64-01	RELAY		1	
57	594 56 01-01	GASKET		1	
58	595 12 95-01	STUD		2	
62	594 30 65-01	STARTER		1	
65	594 30 68-01	LEVER		1	

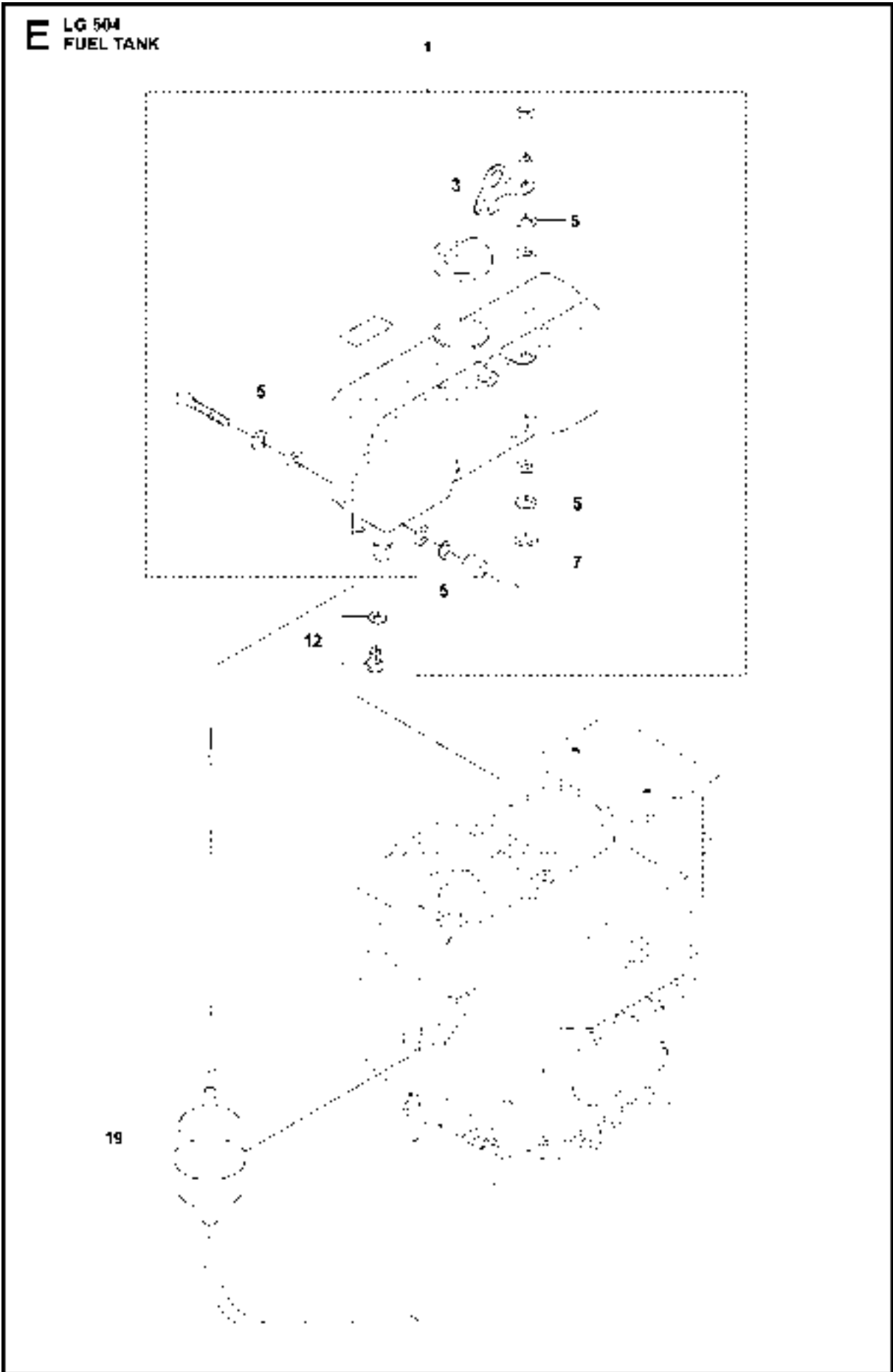

FUEL TANK LG 504, 967855501, 967855502, 967855503, 967855504, 967855505, 967855506, 967855507, 967855508, 967855509, 967855510, 967855511, 967855512, 2019-08

Ref	Part No	Description	Remark	QTY	KIT
1	594 20 77-01	FUEL TANK		1	
3	594 30 92-01	CAP		1	1
5	594 57 38-01	WASHER		12	1
7	594 57 40-01	SPACER		6	1
12	594 58 32-01	WATER SEPARATOR		1	
19	594 57 99-01	FUEL FILTER		1	

F LG 504
CENTRIFUGAL CLUTCH

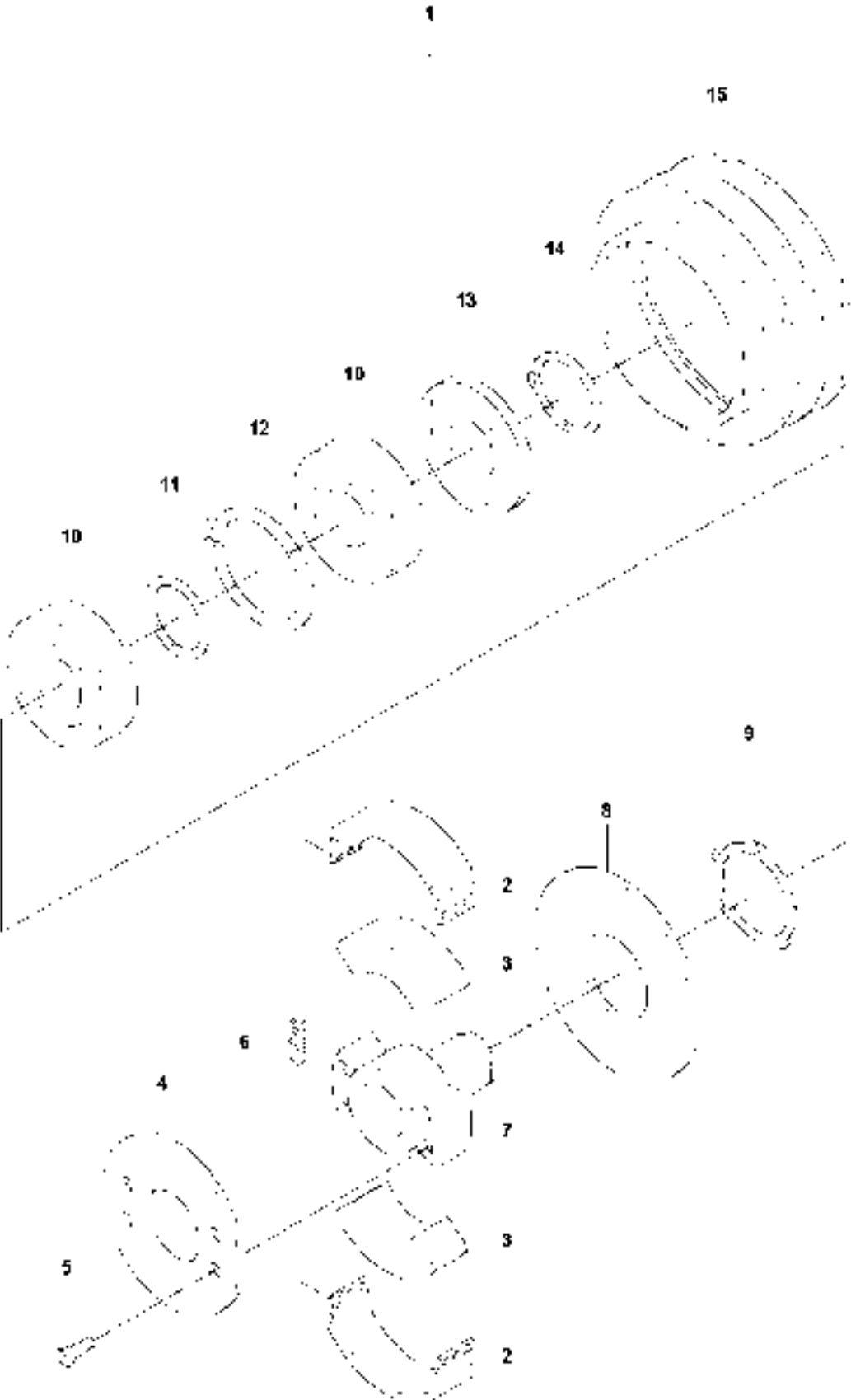

CENTRIFUGAL CLUTCH LG 504, 967855501, 967855502, 967855503, 967855504, 967855505, 967855506, 967855507, 967855508, 967855509, 967855510, 967855511, 967855512, 2019-08

Ref	Part No	Description	Remark	QTY	KIT
1	594 64 68-01	CLUTCH		1	
2	594 59 33-01	CLUTCH		2	1
3	594 59 32-01	WEIGHT		2	1
4	594 59 34-01	COVER		1	1
5	594 59 35-01	SCREW		4	1
6	594 49 45-01	SPRING		4	1
7	594 59 31-01	HUB		1	1
8	594 59 36-01	COVER		1	1
9	594 59 37-01	LOCKWASHER		1	1
10	594 19 48-01	BALL BEARING		2	1
11	594 59 30-01	WASHER		1	1
12	594 58 44-01	RING		1	1
13	595 06 99-01	RING		1	1
14	594 58 45-01	RING		1	1
15	594 59 29-01	BELT		1	1

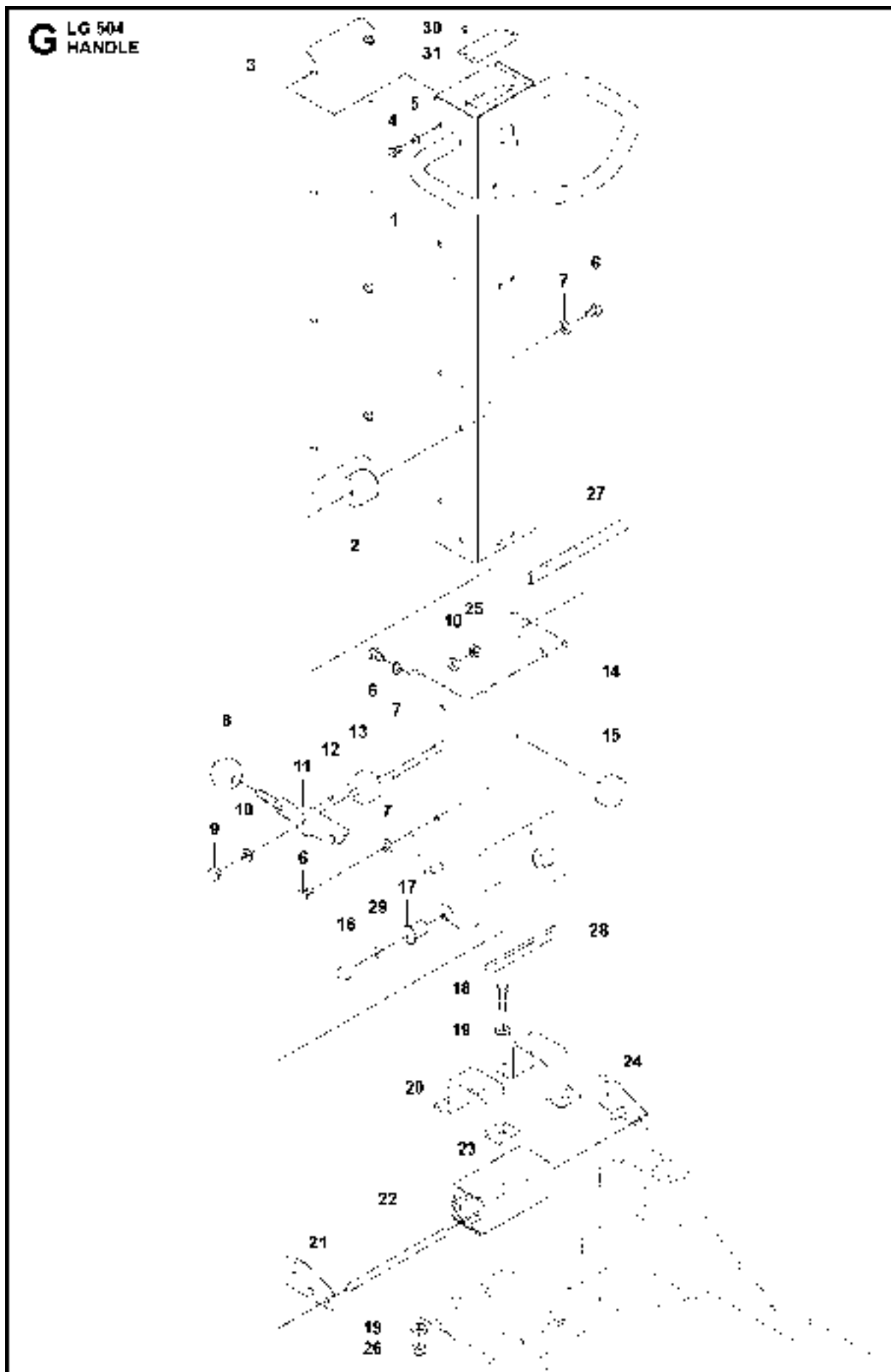

HANDLE LG 504, 967855501, 967855502, 967855503, 967855504, 967855505, 967855506, 967855507, 967855508, 967855509, 967855510, 967855511, 967855512, 2019-08

Ref	Part No	Description	Remark	QTY KIT
1	594 17 55-01	HANDLE		1
2	594 15 30-01	ABSORBER		4
3	594 42 73-01	COVER		1
4	595 05 40-01	SCREW		8
5	595 06 66-01	WASHER		8
6	595 05 51-01	SCREW		9
7	594 74 74-01	WASHER		9
8	594 33 36-01	HANDLE		1
9	594 50 14-01	NUT		1
10	594 74 74-01	WASHER		2
11	594 34 71-01	HOOK		1
12	595 03 08-01	PIN		2
13	594 33 39-01	ABSORBER		1
14	594 15 25-01	HANDLE		1
15	594 33 68-01	STOP		1
16	595 06 00-01	NUT		2
17	594 15 35-01	BUSHING		2
18	594 11 91-01	SCREW		4
19	595 06 79-01	WASHER		8
20	594 15 36-01	CLAMP		2
21	594 15 33-01	RETAINER		1
22	594 15 31-01	STUD		1
23	594 15 32-01	ABSORBER		1
24	594 15 34-01	RETAINER		1
25	595 05 95-01	SCREW		1
26	595 11 27-01	NUT		4
27	595 06 95-01	STRIP		1
28	595 06 48-01	TRIM		1
29	595 11 89-01	LOCKWASHER		12
30	598 08 98-01	COVER		1
31	595 06 56-01	SCREW	M05X10, black	4

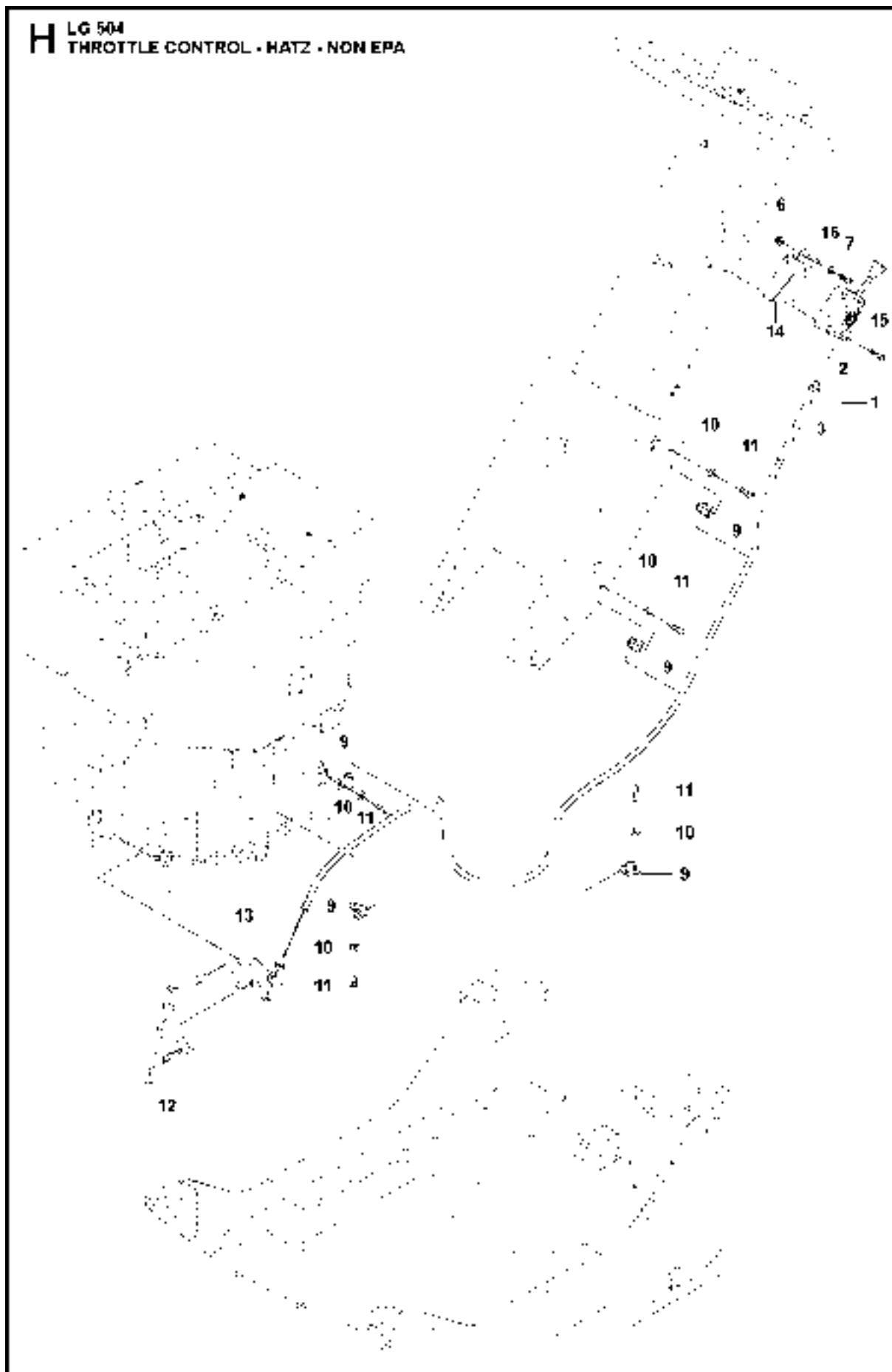

THROTTLE CONTROL - NON EPA LG 504, 967855501, 967855502, 967855503, 967855504,
 967855505, 967855506, 967855507, 967855508, 967855509, 967855510, 967855511, 967855512,

Ref	Part No	Description	Remark	QTY	KIT
1	594 48 30-01	THROTTLE CONTROL		1	
2	594 49 07-01	LEVER		1	1
3	594 48 29-01	THROTTLE CONTROL		1	1
6	595 06 45-01	NUT		1	
7	595 05 78-01	SCREW		1	
9	595 03 75-01	CLAMP		5	
10	595 03 65-01	WASHER		5	
11	595 34 79-01	SOCKET		5	
12	594 33 12-01	NIPPLE		1	
13	595 05 00-01	BRACKET		1	
14	594 64 51-01	BRACKET		1	
15	594 74 71-01	SCREW		4	
16	595 03 65-01	WASHER		1	

J LG 504
THROTTLE CONTROL - HATZ - EPA

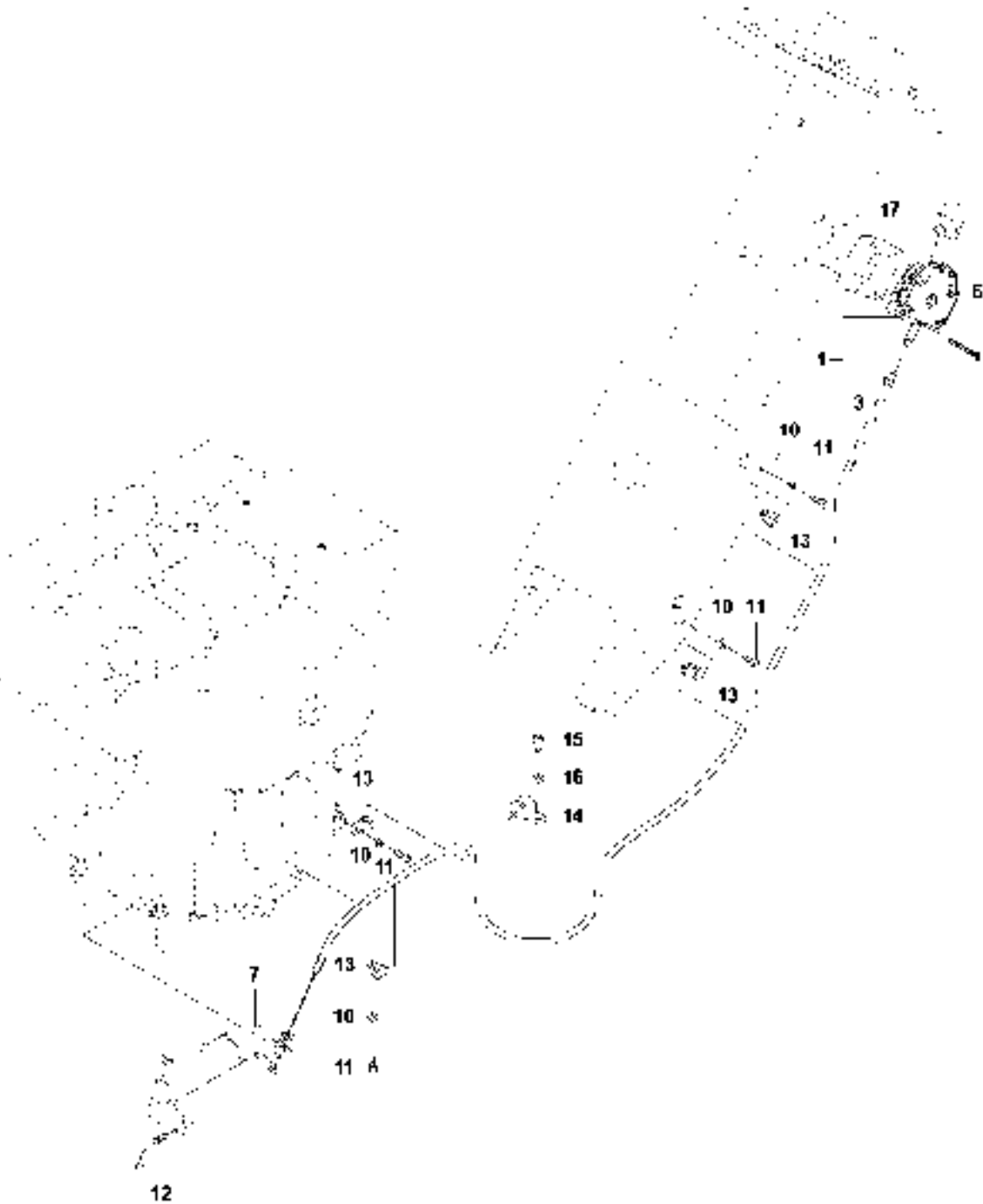

THROTTLE CONTROL - EPA LG 504, 967855501, 967855502, 967855503, 967855504, 967855505, 967855506, 967855507, 967855508, 967855509, 967855510, 967855511, 967855512, 2019-08

Ref	Part No	Description	Remark	QTY	KIT
1	594 17 64-01	THROTTLE CONTROL		1	
3	594 21 02-01	THROTTLE CABLE		1	1
6	595 35 00-01	SCREW	M05 x 55, DIN 7991, H, 8.8 ZnB	4	
7	595 05 00-01	BRACKET		1	
10	595 03 65-01	WASHER		4	
11	595 34 80-01	SCREW		4	
12	594 33 12-01	NIPPLE		1	
13	595 03 75-01	CLAMP		4	
14	595 47 25-01	CLAMP	22.0 8.4 20.0	1	
15	595 03 44-01	SCREW	M8 x 16 DIN 912 - 8.8 zn	1	
16	595 03 66-01	WASHER	M8 DIN125	1	
17	595 37 59-01	SPACER		1	

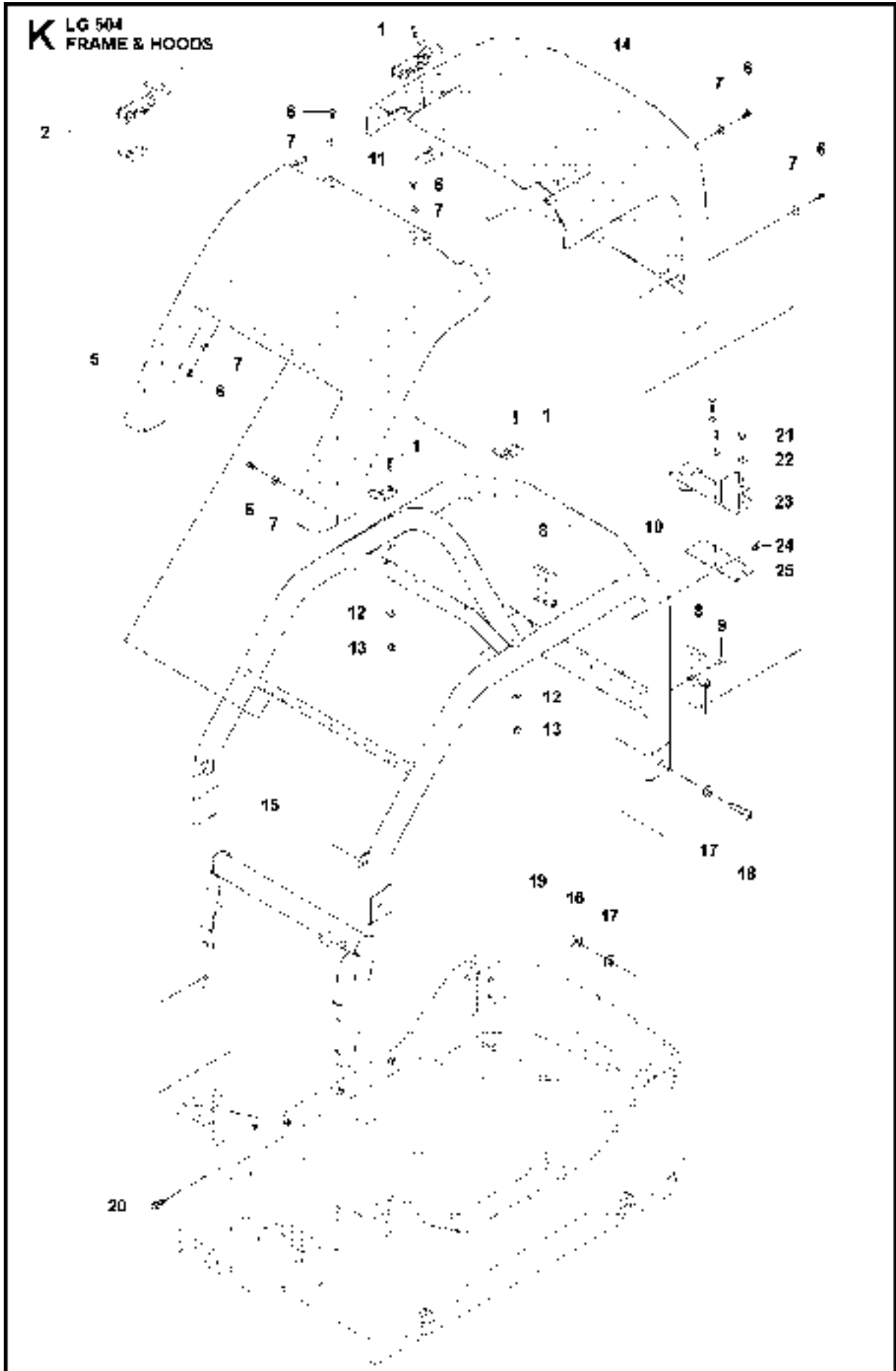

FRAME & HOODS

LG 504, 967855501, 967855502, 967855503, 967855504, 967855505,
967855506, 967855507, 967855508, 967855509, 967855510, 967855511, 967855512, 2019-08

Ref	Part No	Description	Remark	QTY KIT
1	595 11 08-01	SCREW		8
2	594 19 20-01	LATCH		2
5	594 95 78-01	COVER		1
6	595 06 77-01	SCREW	M6x12 black	14
7	594 53 51-01	WASHER	6 x 18 x 2 mm, 0.24 x 0.71 x 0.08 in. 300 HV	14
8	594 44 68-01	HINGE		2
9	594 53 49-01	SCREW		8
10	594 18 01-01	FRAME		1
11	594 19 16-01	STOP		2
12	595 06 78-01	WASHER		4
13	595 06 92-01	LOCK NUT		4
14	594 95 78-01	COVER		1
15	594 18 06-01	BEAM		1
16	594 54 86-01	NUT		4
17	595 11 34-01	WASHER	DIN 125, 13 x 24 x 2,5	8
18	595 11 14-01	SCREW		4
19	594 75 67-01	ENGINE PLATE		1
20	594 11 99-01	SCREW	M8 x 20 mm 8.8 A2K	4
21	596 88 97-19	SCREW	M8 x 12	3
22	595 03 66-01	WASHER		3
23	594 33 04-01	CRANK		1
24	594 53 49-01	SCREW	M06 x 16H, A2-70, Black	2
25	595 12 71-01	BRACKET		1

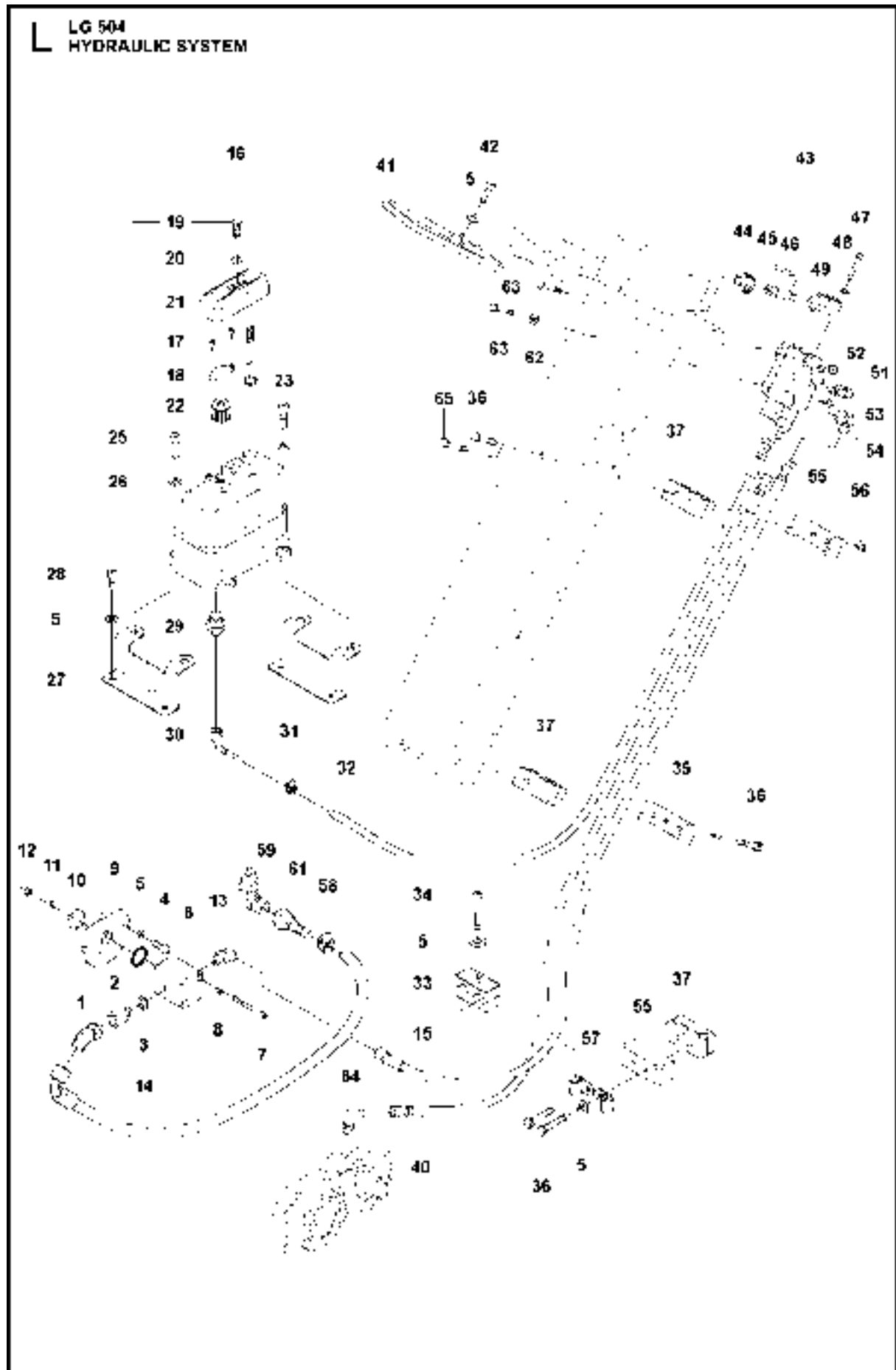

HYDRAULIC SYSTEM LG 504, 967855501, 967855502, 967855503, 967855504, 967855505, 967855506, 967855507, 967855508, 967855509, 967855510, 967855511, 967855512, 2019-08

Ref	Part No	Description	Remark	QTY	KIT
1	595 11 70-01	NIPPLE		1	
2	594 21 96-01	CONNECTION		1	
3	595 35 47-01	WASHER		1	
4	595 34 83-01	SOCKET		2	
5	595 03 66-01	WASHER		9	
6	594 18 63-01	HYDRAULIC PUMP		1	
7	595 34 77-01	SOCKET		2	
8	594 12 38-01	PLANE WASHER		2	
9	595 12 80-01	ADAPTER		1	
10	594 52 01-01	ADAPTER		1	
11	595 03 65-01	WASHER		2	
12	595 28 75-01	HEXAGON NUT		1	
13	594 52 01-01	ADAPTER		1	
14	594 18 58-01	HYDRAULIC HOSE		1	
15	594 18 60-01	HYDRAULIC HOSE		1	
16	594 42 63-01	HYDRAULIC TANK		1	
17	594 83 88-01	SCREW		2	16
18	594 44 54-01	FILTER HOLDER		1	16
19	595 03 34-01	SCREW		1	16
20	595 06 66-01	WASHER		1	16
21	594 44 31-01	COVER		1	16
22	594 44 55-01	AIR FILTER		1	16
23	595 04 73-01	O-RING		1	16
25	594 12 07-01	SCREW		4	
26	594 74 74-01	WASHER		4	
27	595 36 72-01	BRACKET		2	
28	595 03 44-01	SCREW		4	
29	595 11 64-01	NIPPLE		1	
30	594 12 76-01	HOSE COUPLING		1	
31	595 16 07-01	HOSE CLAMP		1	
32	594 18 13-01	HYDRAULIC HOSE		1	
33	594 45 52-01	HOSE		1	
34	594 12 04-01	SOCKET		1	
35	594 14 74-01	BRACKET		1	
36	595 05 58-01	SCREW		8	
37	594 32 40-01	BLOCK		3	
40	594 18 11-01	HYDRAULIC HOSE		1	
41	594 64 26-01	CONTROL LEVER		1	
42	595 03 45-01	SCREW		1	
43	594 18 59-01	VALVE		1	
44	594 20 89-01	COVER		1	43
45	594 20 88-01	LEVER		1	43
46	594 20 87-01	PIN		1	43
47	594 20 90-01	SCREW		2	43
48	594 20 91-01	WASHER		2	43
49	594 20 86-01	LEVER		1	43
51	594 20 96-01	NIPPLE		1	43
52	595 03 60-01	LOCK NUT		1	
53	595 11 26-01	NUT		1	
54	594 12 73-01	CONNECTOR		3	
55	594 14 74-01	BRACKET		2	
56	595 35 16-01	NUT		2	
57	594 12 53-01	PIPE CLAMP	13.0 8.4 20.0	2	
58	595 45 47-01	CLAMP	015-025, 12	1	
59	594 18 61-01	CONNECTOR		1	
61	594 18 62-01	HOSE CONNECTOR		1	
62	595 11 35-01	WASHER	Conical, 6,4 x 14	2	
63	595 28 71-01	SCREW	M08 x 50, 8.8, A2K	1	
64	594 12 75-01	NIPPLE		1	
65	595 05 57-01	SCREW	M8-1,25 x 55 8.8 (LG 504 w/ compaction indicator only)	8	

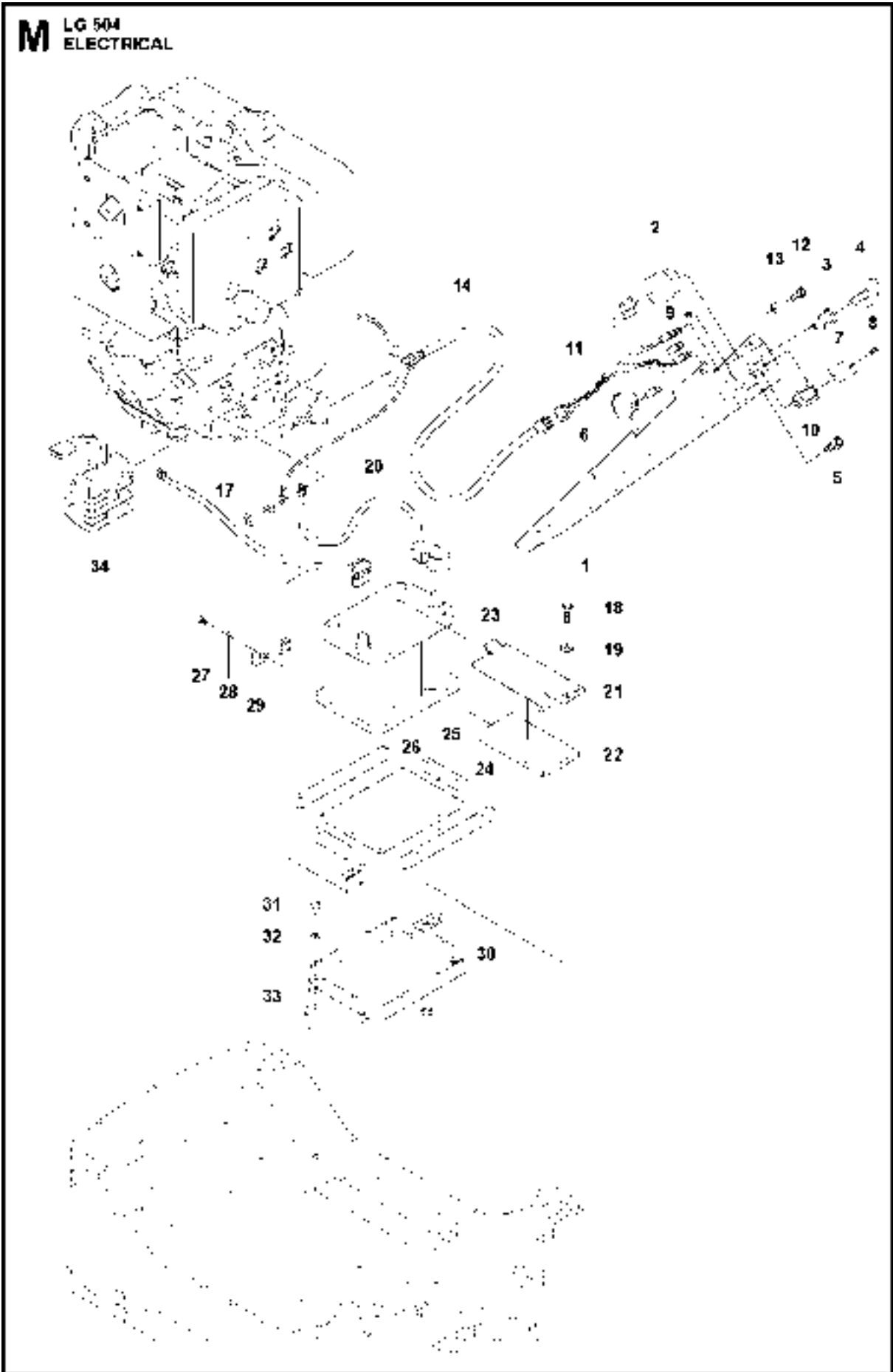

ELECTRICAL LG 504, 967855501, 967855502, 967855503, 967855504, 967855505, 967855506, 967855507, 967855508, 967855509, 967855510, 967855511, 967855512, 2019-08

Ref	Part No	Description	Remark	QTY KIT
1	594 43 22-01	CONTROL PANEL		1
2	595 04 87-01	SWITCH		1
3	594 53 36-01	IGNITION SWITCH		1
4	595 07 01-01	KEY		1
5	594 51 37-01	DIODE		2
6	594 46 34-01	BUZZER		1
7	594 42 67-01	COVER		1
8	595 06 56-01	SCREW	M5 x 10	2
9	595 47 00-01	NUT		2
10	594 82 71-01	HOUR METER	Hour meter	1
11	594 43 23-01	CABLE		1
12	595 05 40-01	SCREW		7
13	595 06 66-01	WASHER	8.4 x 6x1.5 mm 300HV	7
14	594 34 72-01	CABLE		1
17	594 18 74-01	CABLE	(+)	1
18	594 11 86-01	SCREW		1
19	594 74 73-01	WASHER		1
20	594 33 07-01	CABLE	(-)	1
21	594 18 05-01	HOLDER		1
22	594 43 49-01	INSULATION		1
23	594 48 59-01	BATTERY		1
24	595 36 82-01	INSULATION		2
25	595 36 83-01	INSULATION		2
26	594 18 10-01	INSULATION		1
27	595 34 78-01	SOCKET	M6 x 10 ISO 4762	2
28	595 03 65-01	WASHER		2
29	595 11 46-01	PIPE CLAMP		2
30	595 36 69-01	HOLDER		1
31	595 11 01-01	SCREW	m8 x 16	4
32	595 03 66-01	WASHER	DIN 125	4
33	594 18 72-01	ABSORBER		4
34	594 60 64-01	RELAY		1

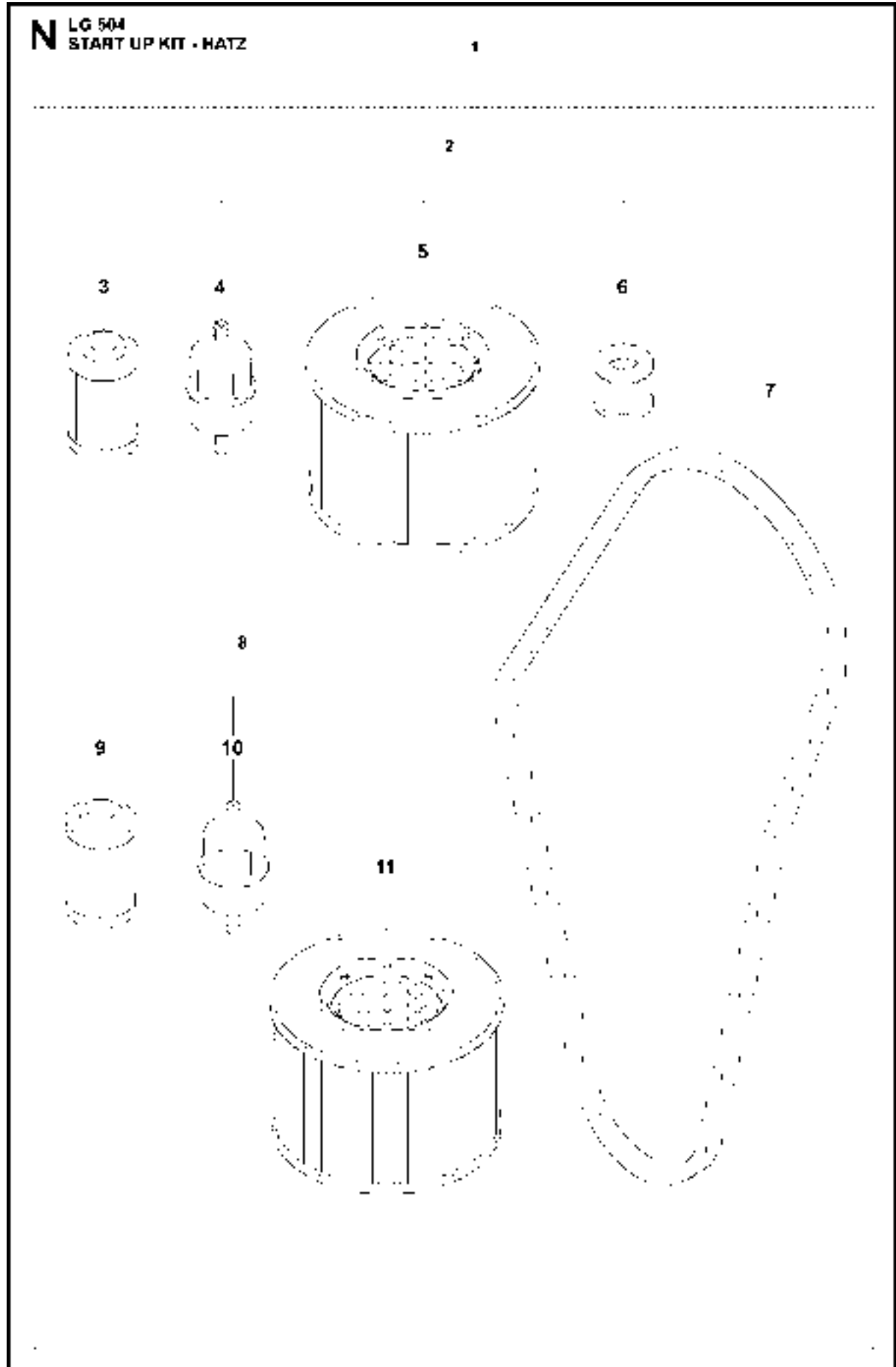

START UP KIT LG 504, 967855501, 967855502, 967855503, 967855504, 967855505, 967855506, 967855507, 967855508, 967855509, 967855510, 967855511, 967855512, 2019-08

Ref	Part No	Description	Remark	QTY KIT
1	594 21 84-01	SERVICE KIT	Start up kit, Hatz 1D81Z + 250 hours, 6 months	1
2	594 21 72-01	SERVICE KIT	Service kit, Hatz 1D81Z	1 1
3	594 30 24-01	OIL FILTER		1 1, 2
4	594 57 99-01	FUEL FILTER		1 1, 2
5	594 30 54-01	AIR FILTER		1 1, 2
6	594 44 55-01	AIR FILTER	Donaldson (small air filter in the Hydraulic oil tank)	1 1, 2
7	594 18 91-01	V-BELT	V-belt XPA 1208(6T43)	2 1, 2
8	594 21 50-01	SERVICE KIT	Service kit 250 hours, 6 months	1 1
9	594 30 24-01	OIL FILTER		1 1, 8
10	594 57 99-01	FUEL FILTER		1 1, 8
11	594 30 54-01	AIR FILTER		1 1, 8

P LG 504
12 MONTHS / 500 HOURS SERVICE KIT - HATZ

1

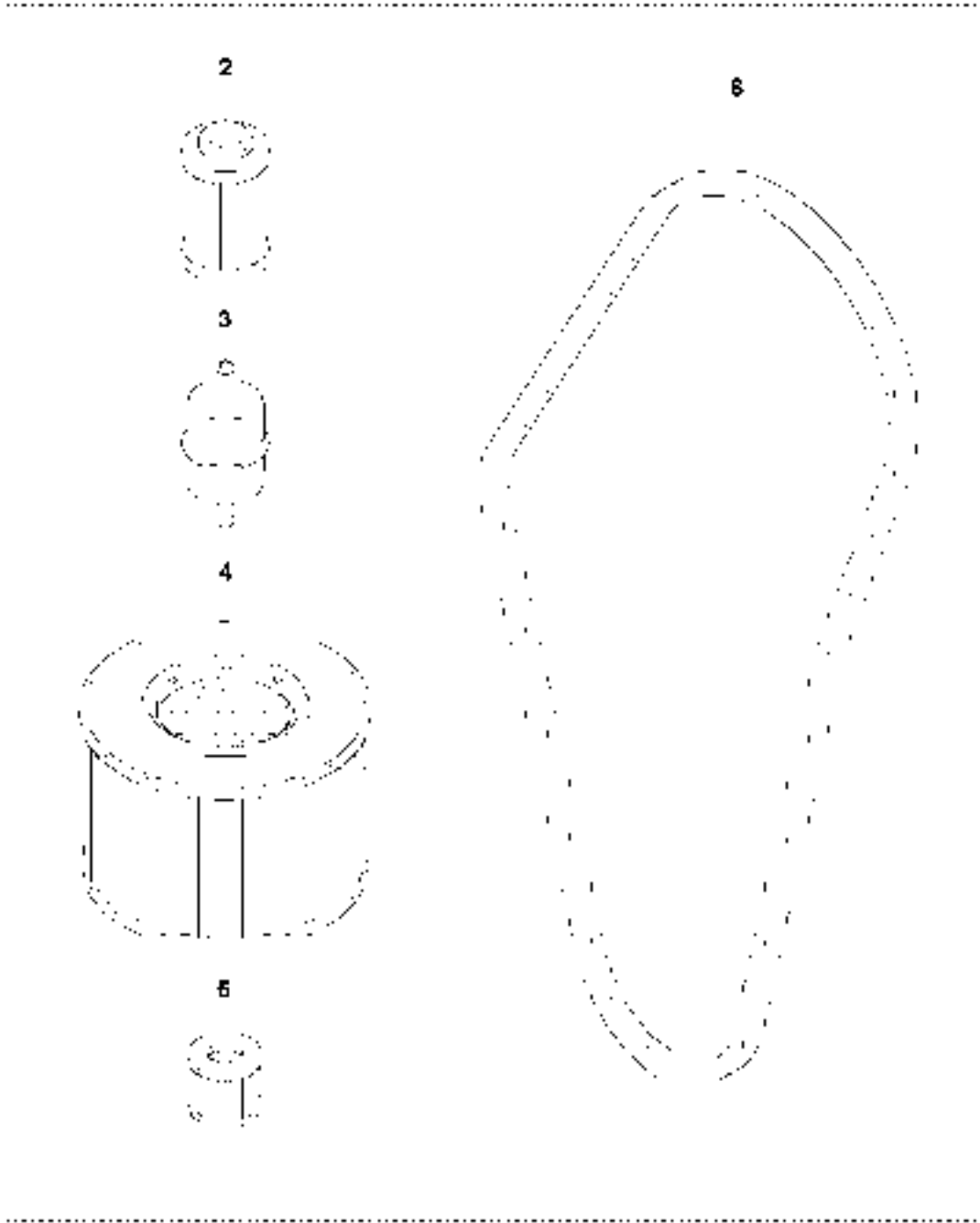

12 MONTHS / 500 HOURS SERVICE KIT LG 504, 967855501, 967855502, 967855503, 967855504, 967855505, 967855506, 967855507, 967855508, 967855509, 967855510, 967855511, 967855512,

Ref	Part No	Description	Remark	QTY KIT	
1	594 21 72-01	SERVICE KIT	Service kit, Hatz 1D81Z	1	
2	594 30 24-01	OIL FILTER		1	1
3	594 57 99-01	FUEL FILTER		1	1
4	594 30 54-01	AIR FILTER		1	1
5	594 44 55-01	AIR FILTER	Donaldson (small air filter in the Hydraulic oil tank)	1	1
6	594 18 91-01	V-BELT	V-belt XPA 1208(6T43)	2	1

SIX MONTHS / EVERY 250 HOURS KIT LG 504, 967855501, 967855502, 967855503, 967855504, 967855505, 967855506, 967855507, 967855508, 967855509, 967855510, 967855511, 967855512, 2019-08

Q LG 504
SIX MONTHS / EVERY 250 HOURS SERVICE KIT - HATZ

1

2

3

4

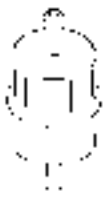

SIX MONTHS / EVERY 250 HOURS KIT LG 504, 967855501, 967855502, 967855503, 967855504, 967855505, 967855506, 967855507, 967855508, 967855509, 967855510, 967855511, 967855512,

Ref	Part No	Description	Remark	QTY KIT
1	594 21 50-01	SERVICE KIT	Service kit 250 hours, 6 months	1
2	594 30 24-01	OIL FILTER		1 1
3	594 57 99-01	FUEL FILTER		1 1
4	594 30 54-01	AIR FILTER		1 1

R LG 504
SHOCK ABSORBER REPAIR KIT

1

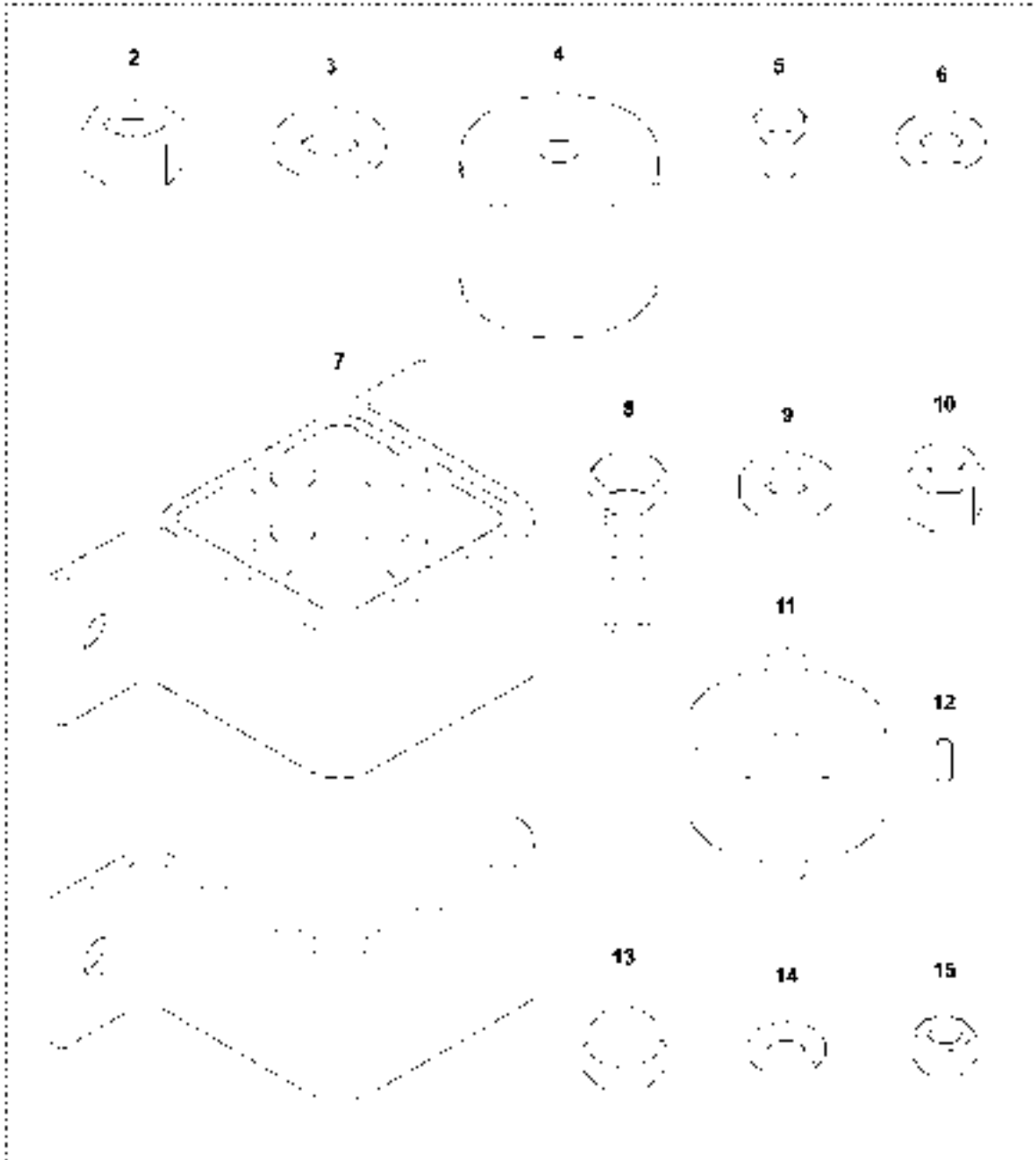

SHOCK ABSORBER REPAIR KIT LG 504, 967855501, 967855502, 967855503, 967855504, 967855505, 967855506, 967855507, 967855508, 967855509, 967855510, 967855511, 967855512,

Ref	Part No	Description	Remark	QTY KIT	
1	595 38 45-01	REPAIR KIT		1	
2	595 03 58-01	NUT	M16 x 2,00, -8, A3K	8	1
3	595 03 67-01	WASHER	M16 17,0x30x3,0 300 HV	8	1
4	594 15 30-01	ABSORBER		4	1
5	595 34 46-01	SCREW	M10 x 16	8	1
6	594 74 74-01	WASHER	M10 10,5x22x2,0 300 HV	8	1
7	594 15 32-01	ABSORBER	DR-A 45x150	1	1
8	594 11 91-01	SCREW	M12 x 040H, 8.8, A3K	4	1
9	595 06 79-01	WASHER	M12 13,0x24x4,0 200-300 HV	8	1
10	595 11 27-01	NUT	M12 ISO7040	4	1
11	594 33 39-01	ABSORBER	A50/25 M10x20 NR60	1	1
12	595 03 08-01	PIN	4 x 12	2	1
13	594 50 14-01	NUT	M10-1,5	1	1
14	594 74 73-01	WASHER	M10 10,5x22x4,0 300 HV,STD277	2	1
15	595 02 94-01	NUT	M10 DIN 934-8 Zn	1	1

S LG 504
ECCENTRIC ELEMENT REPAIR KIT

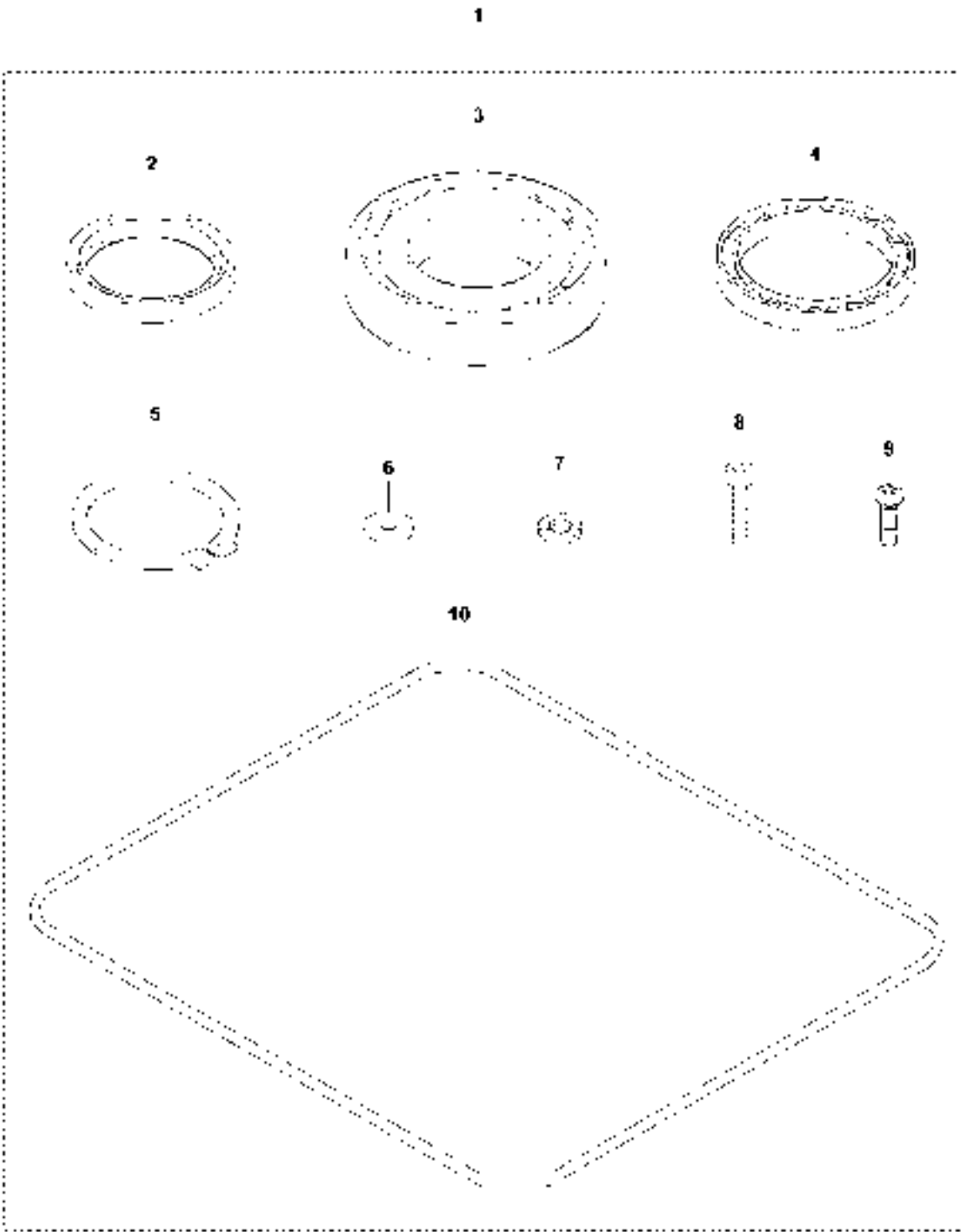

ECCENTRIC ELEMENT REPAIR KIT LG 504, 967855501, 967855502, 967855503, 967855504,
 967855505, 967855506, 967855507, 967855508, 967855509, 967855510, 967855511, 967855512,

Ref	Part No	Description	Remark	QTY KIT	
1	595 39 02-01	REPAIR KIT		1	
2	594 18 42-01	RADIAL SEAL		1	1
3	594 18 34-01	BEARING		4	1
4	594 54 76-01	BALL BEARING		2	1
5	595 03 74-01	CIRCLIP		1	1
6	595 03 64-01	WASHER	Ø6.4x18x1.6	8	1
7	594 12 46-01	WASHER	Nordlock NL6 M6 DIA 13.5	16	1
8	595 28 74-01	SCREW		16	1
9	598 04 63-01	SCREW		8	1
10	594 75 99-01	O-RING		1	1

T LG 504
FORWARD AND REVERSE PISTON REPAIR KIT

1

2



3



4



5



6



7



8

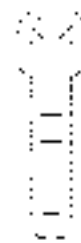

9



10



11

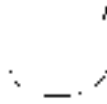

FORWARD & REVERSE PISTON REPAIR KIT LG 504, 967855501, 967855502, 967855503,
 967855504, 967855505, 967855506, 967855507, 967855508, 967855509, 967855510, 967855511,

Ref	Part No	Description	Remark	QTY KIT	
1	595 39 03-01	REPAIR KIT			
2	594 18 43-01	SEALING		1	1
3	595 11 39-01	CIRCLIP		1	1
4	594 18 36-01	BALL BEARING		2	1
5	595 04 63-01	RING		1	1
6	595 03 11-01	PIN	Ø6 x 20 mm DIN 1481	6	1
7	594 12 46-01	WASHER		4	1
8	595 28 74-01	SCREW		4	1
9	594 64 30-01	CAP		1	1
10	594 18 23-01	PISTON ROD		1	1
11	594 18 24-01	PISTON		1	1

BLOCK PAVING PLATE KIT 700 MM LG 504, 967855501, 967855502, 967855503, 967855504, 967855505, 967855506, 967855507, 967855508, 967855509, 967855510, 967855511, 967855512, 2019-08

U LG 504
BLOCK PAVING PLATE KIT 700 MM (27.6")

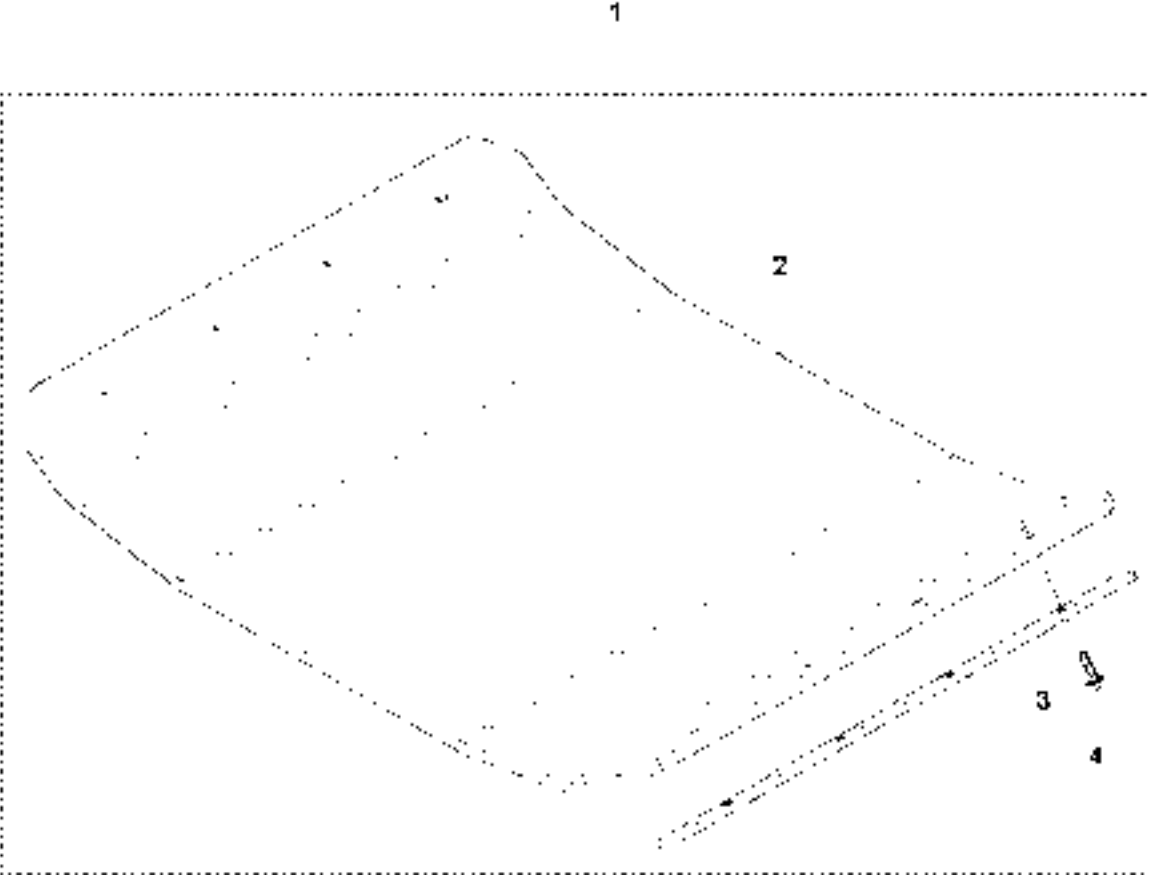

BLOCK PAVING PLATE KIT 700 MM LG 504, 967855501, 967855502, 967855503, 967855504, 967855505, 967855506, 967855507, 967855508, 967855509, 967855510, 967855511, 967855512,

Ref	Part No	Description	Remark	QTY KIT	
1	595 12 89-01	BLOCK	Block-paving kit 950x700 mm option	1	
2	594 75 90-01	PLATE	700 mm, 27.6"	1	1
3	594 44 69-01	BRACKET		2	1
4	594 11 98-01	SCREW	M08 x 30, 8.8, A2K	8	1

EXTENSION PLATE KIT 2 X 75 MM LG 504, 967855501, 967855502, 967855503, 967855504, 967855505, 967855506, 967855507, 967855508, 967855509, 967855510, 967855511, 967855512, 2019-08

V LG 504
EXTENSION PLATE KIT 2 X 75 MM (2X 2.95")

1

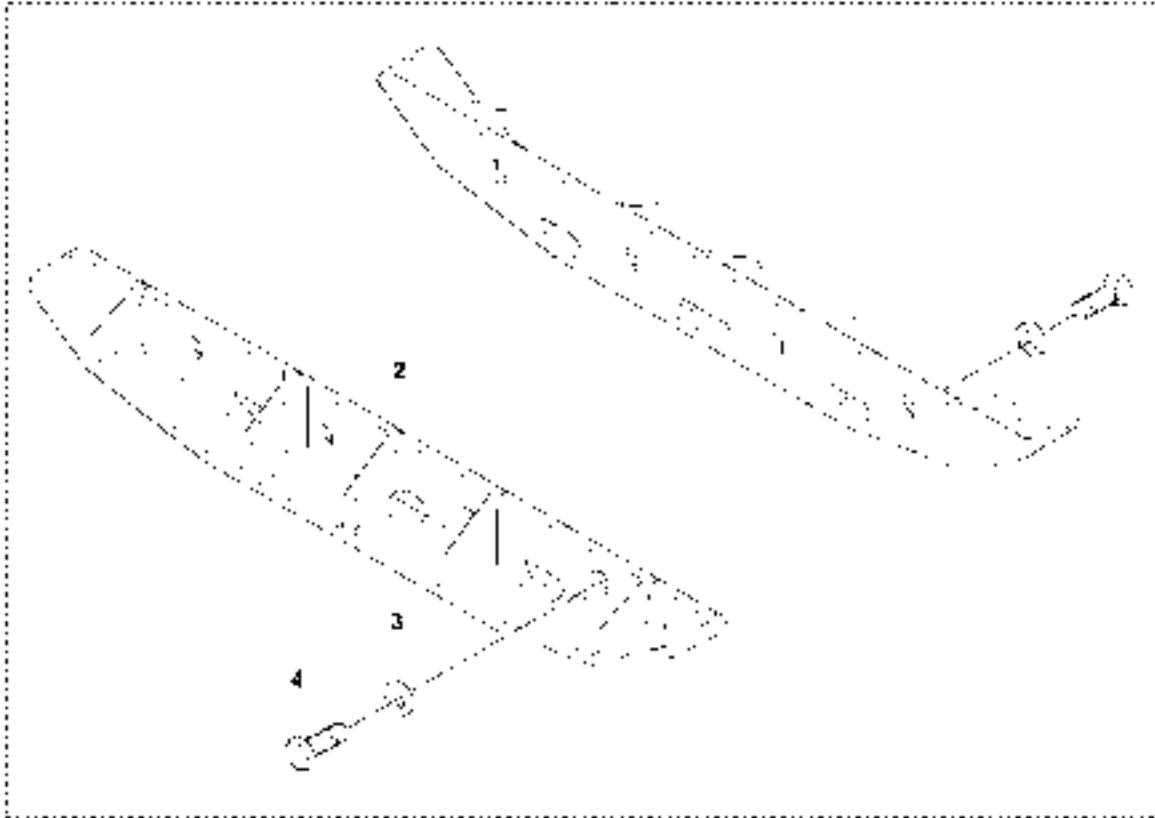

EXTENSION PLATE KIT 2 X 75 MM LG 504, 967855501, 967855502, 967855503, 967855504,
967855505, 967855506, 967855507, 967855508, 967855509, 967855510, 967855511, 967855512,

Ref	Part No	Description	Remark	QTY KIT	
1	594 75 87-01	PLATE		1	
2	595 12 87-01	PLATE	75 mm, 2.95 in.	2	1
3	595 06 52-01	WASHER	21 x 36 x 6 mm, 0.83 x 1.42 x 0.24 300 HV	8	1
4	594 11 94-01	SCREW	M20 x 50 mm 8.8 A9K	8	1

EXTENSION PLATE KIT 2 X 150 MM LG 504, 967855501, 967855502, 967855503, 967855504, 967855505, 967855506, 967855507, 967855508, 967855509, 967855510, 967855511, 967855512, 2019-08

W LG 504
EXTENSION PLATE KIT 2 X 150 MM [5 X 5.90"]

1

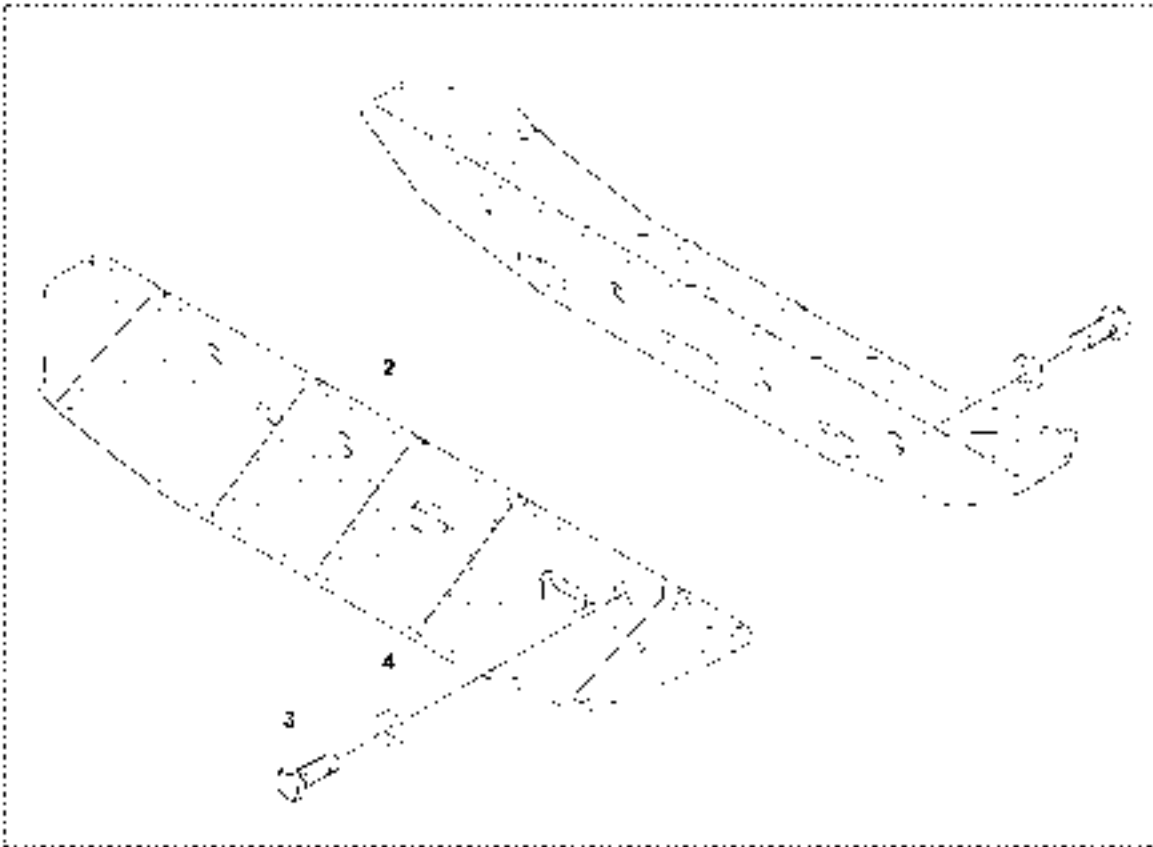

EXTENSION PLATE KIT 2 X 150 MM LG 504, 967855501, 967855502, 967855503, 967855504, 967855505, 967855506, 967855507, 967855508, 967855509, 967855510, 967855511, 967855512,

Ref	Part No	Description	Remark	QTY KIT	
1	594 75 88-01	PLATE		1	
2	594 18 87-01	PLATE	"150 mm, 5.90""	2	1
3	594 11 94-01	SCREW	M20 x 50 mm 8.8 A9K	8	1
4	595 06 52-01	WASHER	21 x 45 mm, 0.83 x 0.87 x 1.77 in. 300 HV	8	1

HOUR METER LG 504, 967855501, 967855502, 967855503, 967855504, 967855505, 967855506, 967855507, 967855508, 967855509, 967855510, 967855511, 967855512, 2019-08

**X LG 504
HOUR METER**

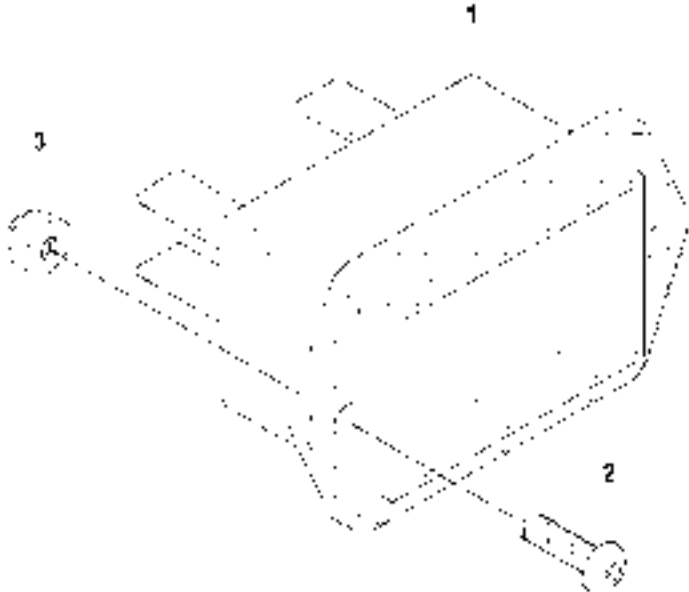

HOUR METER LG 504, 967855501, 967855502, 967855503, 967855504, 967855505, 967855506, 967855507, 967855508, 967855509, 967855510, 967855511, 967855512, 2019-08

Ref	Part No	Description	Remark	QTY KIT
1	594 82 71-01	HOUR METER	LCD 3-terminal, enable 2-screw	1
2	595 06 56-01	SCREW	Screw M3 x 10 mm black	2
3	595 47 00-01	NUT	nut M3	2

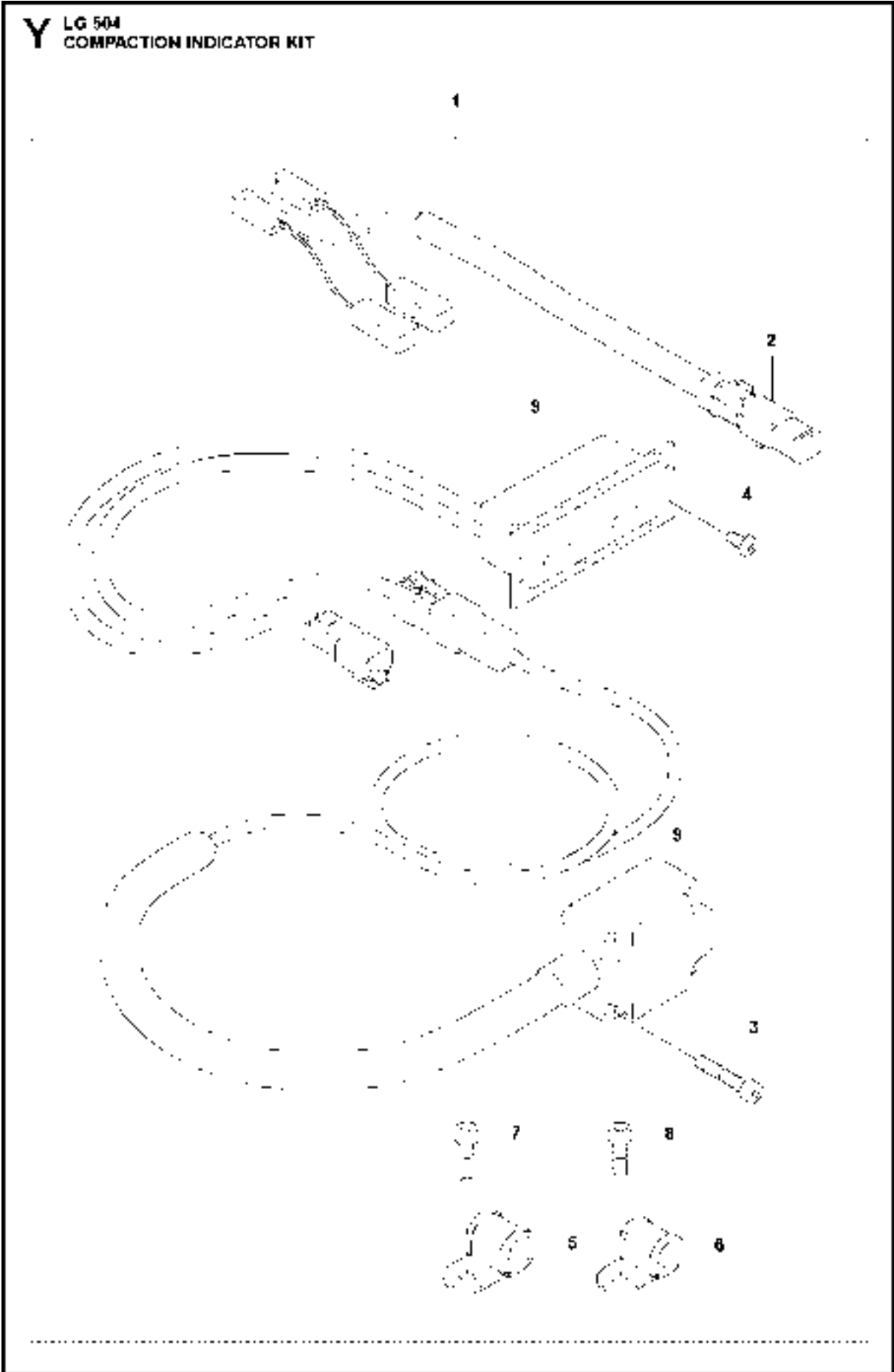

COMPACTION INDICATOR KIT LG 504, 967855501, 967855502, 967855503, 967855504,
 967855505, 967855506, 967855507, 967855508, 967855509, 967855510, 967855511, 967855512,

Ref	Part No	Description	Remark	QTY KIT	
1	594 76 17-01	INDICATOR	Compaction indicator kit	1	
2	594 75 57-01	HARNES	Wiring harness	1	1
3	595 11 12-01	SCREW	Screw M06x030H, 8.8, A2K	4	1
4	595 06 56-01	SCREW	Screw M05X10 black	4	1
5	595 11 48-01	PIPE CLAMP	Pipe clamp covered Ø19 x 15 M6	2	1
6	594 12 56-01	PIPE CLAMP	Pipe clamp covered Ø16 M6	1	1
7	595 03 48-01	SCREW	Screw M6x20(10)	2	1
8	595 03 42-01	SCREW	Screw M6x16(10)	1	1
9	594 18 77-01	INDICATOR		1	1

Z LG 504 GOLD KIT		1	
1	59530370*	Gold Kit LG 504 Hatz	
Ground Plate -Eccentric-Handling System LG E04 Hatz			
2	Eccentric System	Shock absorber repair kit	1
3		eccentric element repair kit	1
4		Forward and reverse position repair kit	1
5		V-Belt Pulley	1
6		Clutch	1
7		Hydraulic hose	1
8		Hydraulic hose	1
9		Hydraulic hose	1
10		Hydraulic hose	1
Cosmetic Kit LG C04 Hatz			
11	Case	Cap, complete	1
12		Hex lock screw	5
13		Front hood	1
14		Rear hood	1
15	Cap Cover	Lubrication sockets screws, M10x2	1
16		Washer	1
17		Cap, complete	1
18		V belt cover	1
19		Cap, complete	1
20		Pin	2
21		Washer	5
22		Cover	1
23		Cap, complete	1
24		Hub gear washer	1
25	Hub Protection	Hub protection	1
26		Spacers, 20mm	1
27		Spacers, 15mm	1
28		Screw	1
29		Washer	2
30		Hex socket screw	1
31	Hub Lid	Washer	1
32		Screw	1
33		Hubber cover	1
34		Level	1
35		housing	1
36		Measuring nipple	1
37		Screw	2
38		Washer	2
39		Pin	1
40		Lubrication	Lubrication Kit, 500g, 100g, 100g, 100g
Engine			
41	Hatz Engine	Yearly Service Kit	1

GOLD KIT LG 504, 967855501, 967855502, 967855503, 967855504, 967855505, 967855506,
967855507, 967855508, 967855509, 967855510, 967855511, 967855512, 2019-08

Ref	Part No	Description	Remark	QTY KIT
1	595 38 97-01	SERVICE KIT		1

AA LG 504
SILVER KIT

1

1	Kit (Sill)	Silver Kit LG 504 Hatz	
Ground Plate -Eccentric-Handling System LG 504 Hatz			
2	Eccentric System	Shock absorber repair kit	
3		Eccentric element repair kit	
4		Roller wheel leveling piston repair kit	
5		V-Roll Pulley	
6		Clutch	
7		Hydraulic Hose	
8		Hydraulic Hose	
9		Hydraulic Hose	
10		Hydraulic Hose	
Engine			
11	Hatz Engine	Yearly Service Kit	

SILVER KIT LG 504, 967855501, 967855502, 967855503, 967855504, 967855505, 967855506, 967855507, 967855508, 967855509, 967855510, 967855511, 967855512, 2019-08

Ref	Part No	Description	Remark	QTY KIT
1	595 38 96-01	SERVICE KIT		1

AB LG 504
COSMETIC KIT

1

1	99999999	Cosmetic Kit LG 504 Mats		
2	Cover	Left side plate	1	
3		Right side plate	1	
4		Front hood	1	
5		Rear hood	1	
6		Common head socket screw, M3x13		14
7			Washer	14
8		Cabinet face	Cover left plate	1
9	Mount plate		1	
10	Top cover		1	
11	Screw		4	
12	Washer		4	
13	Protection	Cover	1	
14		NSM Bech	1	
15		Mounting washer	1	
16	Heel Protection	Head protection	1	
17		Sealing material	1	
18		Sealing material	1	
19		Screw	1	
20		Washer	1	
21		Hex socket screw	1	
22	Handle	Handle	1	
23		Screw	1	
24		Rubber cover	1	
25		Insert	1	
26		Housing	1	
27		Mounting plate	1	
28		Screw	1	
29		Washer	1	
30			1	
31	Labeling	Product Label (UG) Schematic (FA)	1	

COSMETIC KIT LG 504, 967855501, 967855502, 967855503, 967855504, 967855505, 967855506, 967855507, 967855508, 967855509, 967855510, 967855511, 967855512, 2019-08

Ref	Part No	Description	Remark	QTY KIT
1	595 13 32-01	SERVICE KIT		1

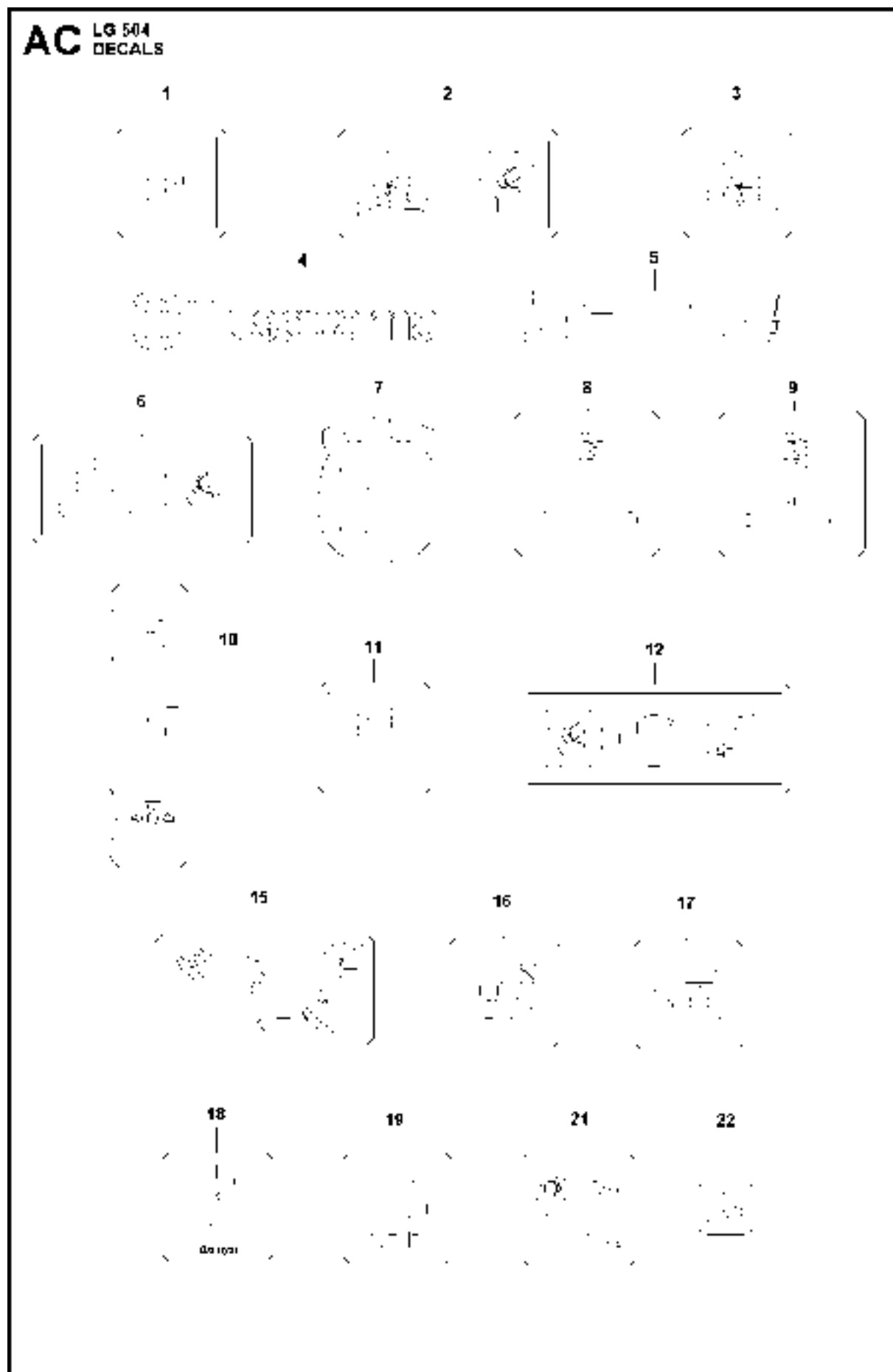

DECALS LG 504, 967855501, 967855502, 967855503, 967855504, 967855505, 967855506, 967855507, 967855508, 967855509, 967855510, 967855511, 967855512, 2019-08

Ref	Part No	Description	Remark	QTY KIT
1	594 66 04-01	LABEL	Engine start	1
2	594 66 06-01	LABEL	Handle lock	1
3	594 66 08-01	LABEL	Rotating parts	1
5	595 09 56-01	DECAL	LG 504 Model Code	2
4	585 29 48-01	DECAL	Husqvarna brand decal	1
6	594 86 97-01	LABEL	General warning	1
7	576 97 34-01	DECAL	Husqvarna crown	1
8	594 66 05-01	LABEL	Gas throttle	1
9	594 66 10-01	LABEL	Gas throttle CTD LG500	1
10	594 66 03-01	LABEL	Battery, hour meter, oil	1
11	594 66 09-01	LABEL	Lifting point	1
12	594 65 96-01	LABEL	Protection	1
15	594 66 07-01	LABEL	Operator panel	1
16	594 86 96-01	LABEL	Engine start manually	1
17	595 51 28-01	LABEL	Hydraulic oil Level	1
18	595 46 94-01	DECAL	biodegradable hydr. oil	1
19	594 66 16-01	LABEL	Diesel	1
21	595 51 32-01	LABEL	Noise 109 DB	1
22	596 28 02-01	DECAL	Compliance RCM	1