

TRABATTELLLO P6 Utility Plus



Trabattello domestico in tutto alluminio di rapido montaggio, reso particolarmente solido e compatto dalle leve Pinna ad espansione.

- 4 ganci di sicurezza sul pianale.
- Base: barra stabilizzatrice con ruote inattive da un lato, dal lato opposto la spalla è parallela a terra con otturatori rigidi ad accogliere due flange in resina morbida a protezione di pavimenti in genere.



Sicurezza:
Ganci anti ribaltamento nei piani di lavoro

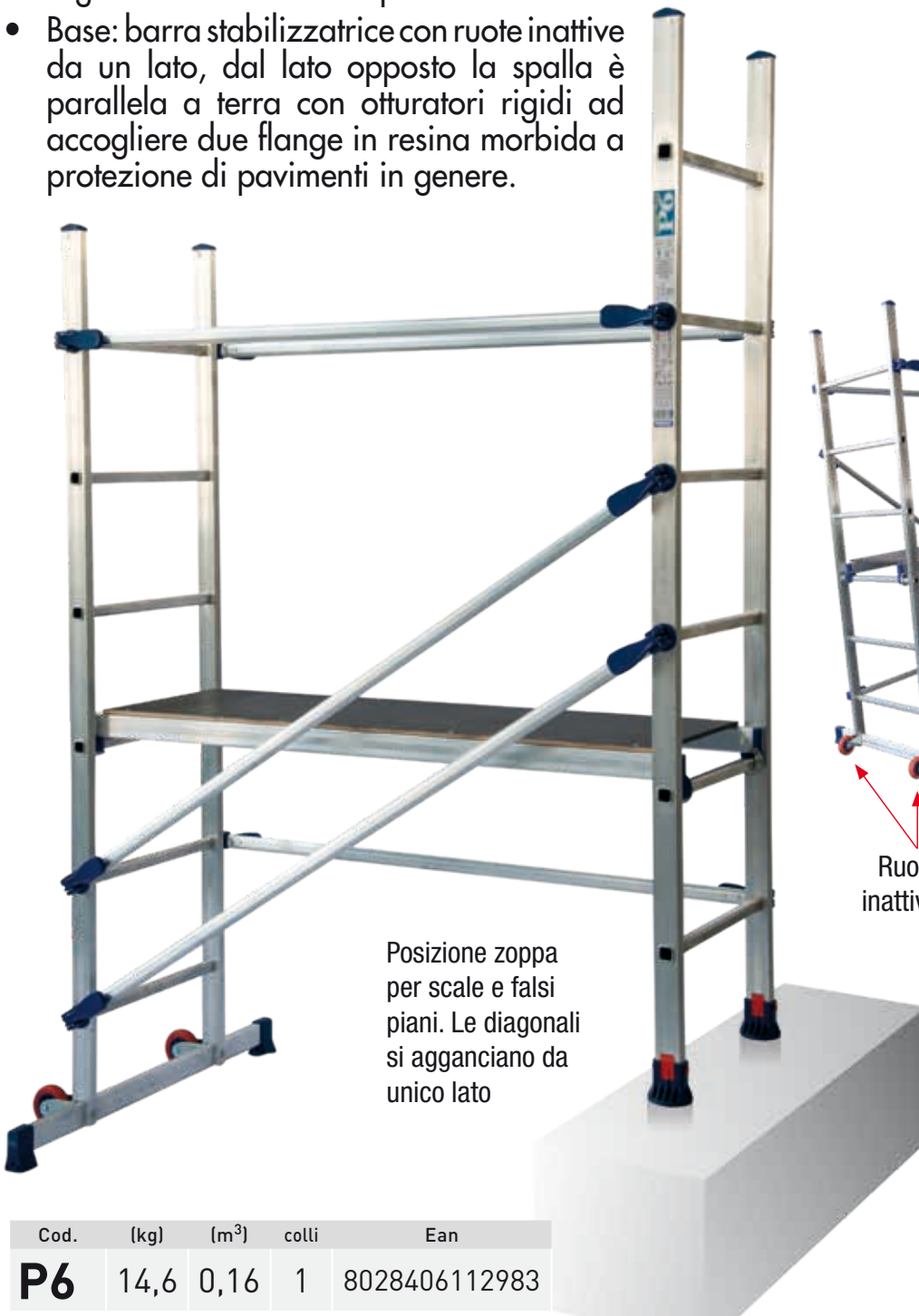

Posizione zoppa per scale e falsi piani. Le diagonali si agganciano da unico lato



290 cm

189 cm

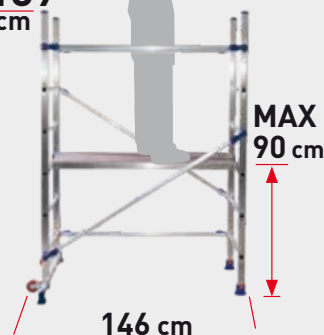

146 cm



| Cod. | (kg) | (m ³) | colli | Ean |
|-----------|------|-------------------|-------|---------------|
| P6 | 14,6 | 0,16 | 1 | 8028406112983 |

81/2008
DECRETO LEGISLATIVO

MADE
IN
ITALY
100%

PIANO LAVORO:
125x41 cm
14,6 kg

Norma
gestione
ecosostenibile
FSC
delle foreste
Sistema legno controllato

Controlled by
FACAL

5 ANNI
GARANZIA

150
kg
MAX



...Qualcosa che vale nel tempo